

Box trailers

Operating Instructions

Part 2 - HK - HGK - TK - HVK



MACHT'S MÖGLICH

en

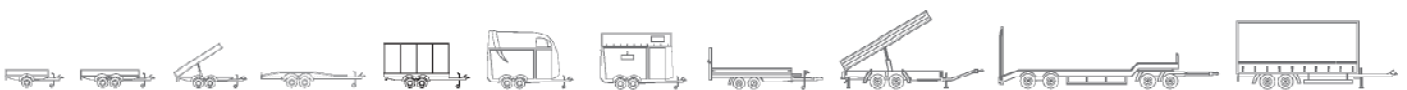

Series 5000 • 5300 • 5500 • 5900

humbaур.com

Name and address of manufacturer:

Humbaur GmbH
Mercedesring 1
86368 Gersthofen
Germany

Tel. +49 821 24929-0
Fax +49 821 249-100

info@humbaur.com
www.humbaur.com

Name and address of dealer:

Name: _____

Address: _____

Telephone: _____

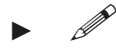

- ▶ Please enter the name of your dealer.

Notes on use / target group



PART 2 - Original - "Box Trailer" Operating Instruction Manual

This "Box Trailer" Operating Instruction Manual Part 2 is intended for you as the user of a ready-to-use trailer.

It provides detailed instructions for handling box trailers.

It contains all the relevant details on safe operation, care / cleaning, maintenance / servicing, troubleshooting and decommissioning / disposal.

This specific operating instruction manual (Part 2) for your trailer is provided on the enclosed CD. You can also download it from

www.humbaur.com in the section: Download - Operating Instructions.

PART 1 - "Trailers up to 3.5 to General Points"

For all other general information on trailers up to 3.5 to, see the operating instruction manual, "Trailers up to 3.5 to (General Points - Part 1)".

- PART 1 and PART 2 together form the complete documentation for your trailer, which you, as the user, should have at your disposal.



Read this operating instruction manual carefully and completely before using your trailer for the first time and observe all of the instructions, safety information and warnings. Comply with the steps for handling.

- Non-observance of any of the documentation can cause injuries to you and to other persons and can cause material damage.
- Non-observance may invalidate your warranty entitlement.
- Keep this operating instruction manual in a safe place for the entire service life of your trailer.
- We advise you to store the operating instruction manual in the driver's cab and to keep it on hand for reference.
- It should be passed on to the new user / owner if you rent out or sell your trailer.





Furthermore, as a road user, you are obliged to observe all national regulations for driving a vehicle with trailer and to comply with your obligations as the owner of a commercial vehicle.

- This includes carrying out regular service and maintenance and periodically subjecting your trailer to a full technical inspection.
- Observe any special stipulations that are specific to your country.

Index

1	Identification	4	7	Driving	53
1.1	Confirmation of compliance	5	7.1	Skylight	53
2	Product description	6	7.2	Sliding window	54
2.1	Box trailer in general (5000)	6	7.3	Vent window	55
2.2	Cool Trailer (5300)	6	7.4	Lights	56
2.3	Freezer box trailer (5500)	6	8	Parking	57
2.4	Sales box trailer (5900)	6	8.1	Parking an uncoupled trailer	57
2.5	Special versions	6	8.2	Manoeuvring	58
2.6	Components	7	8.3	Ventilating / drying the inside	59
2.7	Plywood box	8	8.4	Sales box trailers	60
2.8	Sandwich box	8	8.5	Refrigerated box trailers	60
2.9	Sandwich box, PurFerro	9	8.6	Refrigerating unit (optional)	60
2.10	Cool Trailer (down to 6 °C)	9	8.7	Power generator (optional)	65
2.11	Freezer box trailers (down to -18 °C)	10	8.8	Distributor box (optional)	65
2.12	Sales box trailers	10	8.9	Platform	66
2.13	Optional accessories	11	8.10	Ladder	70
2.14	Special versions	14	8.11	Advertising panel frame	71
3	Intended use	17	9	Cleaning / maintenance / servicing	71
3.1	Box trailers in general	17	9.1	Care / cleaning	71
3.2	Refrigerated box trailers	17	9.2	Maintenance / servicing	72
3.3	Sales box trailers	17	10	Troubleshooting	74
3.4	Special versions	17	11	Decommissioning / disposal	74
4	Foreseeable misuse	17	11.1	Shutdown	74
4.1	Box trailers in general	17	11.2	Disposal	74
4.2	Refrigerated box trailers	17			
4.3	Sales box trailers	17			
4.4	Special versions	17			
5	General Safety Instructions	18			
6	Loading and Unloading	19			
6.1	Load distribution	19			
6.2	Load securing	19			
6.3	Supports	23			
6.4	Door / double-wing door	26			
6.5	Freezer box door with emergency unlocking	29			
6.6	Ramp wall	31			
6.7	Ramp wall + wood/aluminium cover	37			
6.8	Using the ramp wall	40			
6.9	Sales hatch	40			
6.10	Sales counter (standard fittings)	44			
6.11	Roller shutter	45			
6.12	Access door	46			
6.13	Gas bottle compartment	48			
6.14	Cable winch + flap	49			
6.15	Step	52			

1 Identification

- ▶  Put a check mark next to the type of trailer you have acquired.
- ▶  Read the general operating instruction manual for car trailers (PART 1).

Product name: Box trailers

5000 Series:

Plywood box with ramp wall + wood/aluminium cover Single-axle

Type 1: HKU 132513-17P

Plywood box Single-axle

Type 1: HK 132513-15P

Type 2: HK 152513-15P

Type 3: HK 752513-15P

Type 4: HK 133015-18P

Type 5: HK 153015-18P

Plywood box Tandem

Type 1: HK 203015-18P

Type 2: HK 253015-18P

Type 3: HK 203015-20P

Type 4: HK 253015-20P

Sandwich box, PurFerro flatbed trailer Single-axle

Type 1: xxx

Sandwich box flatbed trailer Single-axle

Type 1: HK 752010-15S

Type 2: HK 102010-15S

Type 3: HK 133014-18S

Type 4: HK 752513-15S

Type 5: HK 132513-15S

Type 6: HK 132513-18S

Sandwich box, PurFerro flatbed trailer Tandem

Type 1: HK 254018-20PF18

Sandwich box flatbed trailer Tandem

Type 1: HK 162513-18S

Type 2: HK 202513-18S

Type 3: HK 252513-18S

Type 4: HK 203014-18S

Type 5: HK 253014-18S

Type 6: HK 203016-18S

Type 7: HK 253016-18S

Type 8: HK 203516-18S

Type 9: HK 253516-18S

Type 10: HK 254017-18S

Sandwich box wheels-in trailer Tandem

Type 1: HK 203017-18S

Type 2: HKN 203017-18S

Type 3: HK 253017-18S

Type 4: HKN 253017-18S

Type 5: HK 303017-18S

Type 6: HKN 303017-18S

Type 7: HK 203020-18S

Type 8: HKN 203020-18S

Type 9: HK 253020-18S

Type 10: HKN 253020-18S

Type 11: HK 303020-18S

Type 12: HKN 303020-18S

Type 13: HK 254020-20S

Type 14: HKN 254020-20S

Type 15: HK 304020-20S

Type 16: HKN 304020-20S

Type 17: HK 255020-20S

Type 18: HKN 255020-20S

Type 19: HK 305020-20S

Type 20: HKN 305020-20S

Type 21: HK 355020-20S

Type 22: HK 255024-20S

Type 23: HKN 255024-20S

Type 24: HK 305024-20S

Type 25: HKN 305024-20S

Type 26: HK 355024-20S

Type 27: HK 256020-20S

Type 28: HKN 256020-20S

Type 29: HK 306020-20S

Type 30: HKN 306020-20S

Type 31: HK 356020-20S

Type 32: HK 256024-20S

Type 33: HK 306024-20S

Type 34: HK 356024-20S

Type 35: HK 204017-20S

Type 36: HKN 204017-20S

Type 37: HK 254017-20S

Type 38: HKN 254017-20S

Type 39: HK 304017-20S

Type 40: HKN 304017-20S

1.1 Confirmation of compliance



Humbaur GmbH hereby confirms compliance with all relevant EU directives for the registration and safe use of box trailers of the 5000 • 5300 • 5500 • 5900 series with accessories.

You may request a detailed EU declaration of conformity from us separately.

5300 series

Cool Trailer box trailer

Single-axle

Type 1: HGK 132513-19S50

Cool Trailer box trailer

Tandem

Type 1: HGK 253017-19S50

Type 2: HGK 303017-19S50

Type 3: HGK 253517-19S50

Type 4: HGK 303517-19S50

Type 5: HGK 254017-19S50

Type 6: HGK 304017-19S50

Type 7: HGK 354017-19S50

5500 series

Freezer box trailer

Type 1: TK 252915

Type 2: TK 253415

Type 3: TK 253916

5900 series

Sales box trailer basic model

Type 1: HVK 132921

Type 2: HVK 152921

Type 3: HVK 133421

Type 4: HVK 153421

Type 5: HVK 183421

Type 6: HVK 153921

Type 7: HVK 183921

Type 8: HVK 203421

Type 9: HVK 253421

Type 10: HVK 203921

Type 11: HVK 253921

Sales box trailer

Standard fittings

Type 1: HVKU 132921

Type 2: HVKU 152921

Type 3: HVKU 133421

Type 4: HVKU 153421

Type 5: HVKU 183421

Type 6: HVKU 153921

Type 7: HVKU 183921

Type 8: HVKU 203421

Type 9: HVKU 253421

Type 10: HVKU 203921

Type 11: HVKU 253921

2 Product description

2.1 Box trailer in general (5000)

- The box trailer can be executed as a single-axle trailer or a tandem.
- The body can consist of plywood (15 mm thick) or sandwich panels (45 mm thick).
- The floor plate is 15 mm thick in plywood vehicles and 18 mm thick in sandwich vehicles.
- The box trailer with a closed body, optionally with a double-wing door, ramp wall or wood/aluminium cover, is a means of transport protected from the weather.
- The braked box trailer is equipped with brakes and reverse automatic as standard. It has a parking brake for uncoupled operation.
- The body is protected against theft by means of a lockable closing mechanism.
- The trailer has a 13 pin plug and a reversing and fog light as standard.
- As an option, the trailer can be equipped with tie rails and locking bars in the body as well as tie-down rings on the cargo bed.
- Various supports can also be retrofitted to the chassis to stabilise the body.

2.2 Cool Trailer (5300)

- Possibility of emergency unlocking from the interior of the box.
- The floor plate is 50 mm thick and insulated.
- The side walls made of sandwich panels are 45 mm thick.
- With refrigerating unit for the transport of goods, e.g., beverages, down to a cooling temperature of + 6 °C.
- The Cool Trailer is provisioned with interior equipment, such as interior lighting, scuff protection and non-slip floor covering, etc.

2.3 Freezer box trailer (5500)

- The floor plate is 80 mm thick and insulated.
- The side walls (80 mm thick) are PVC-coated on the inside, food safe, hot-dip galvanised on the outside and provisioned with a polyester paint finish.
- With a refrigerating unit for the transport of perishable goods, such as food, with a cooling temperature of + 10 °C to - 18 °C.
- As an option, a power generator can be fitted to the drawbar to operate the refrigerating unit.
- The freezer box trailer is provisioned with interior equipment, such as a ceiling-rail for meat hooks, interior lighting with switch, scuff protection and non-slip floor covering, etc.

2.4 Sales box trailer (5900)

- The sales box trailer with sales hatch is available as a basic model or with standard fittings.
- The floor plate with a PVC covering is 18 mm thick.
- The side walls as sandwich panels are 45 mm thick, hot-dip galvanised on the outside and provisioned with a polyester paint finish.
- With special interior equipment, such as sales counter, double basin or gas bottle compartment for catering trade.
- The sales box trailer is provisioned with equipment, such as corner legs, step plate on the drawbar as well as an access door at the front.
- As an option, the sales box trailer can be equipped with a power supply with distributor box with sockets, skylight / sliding window, gas bottle compartment and hygiene package, etc.

2.5 Special versions

- Box trailer as a special version for a wide range of applications, such as promotional tours, bicycle transport, car transport and advertising, with appropriate equipment.
- Box trailer with lowerable chassis (SENKO, HKT kneeling trailer) to facilitate driving onto the cargo bed.



Please refer to the separate operating instruction manual of the respective trailer model.



SENKO - box



HKT Kneeling Box Trailer

Illustrated examples

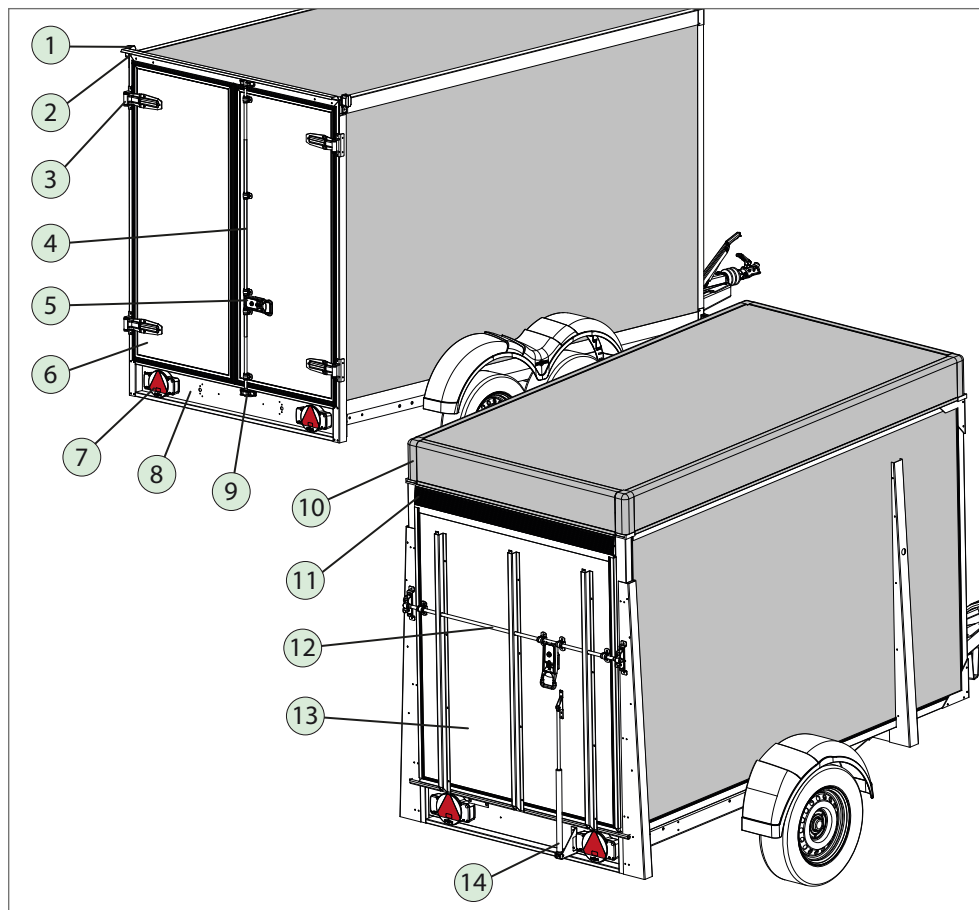

Rear view

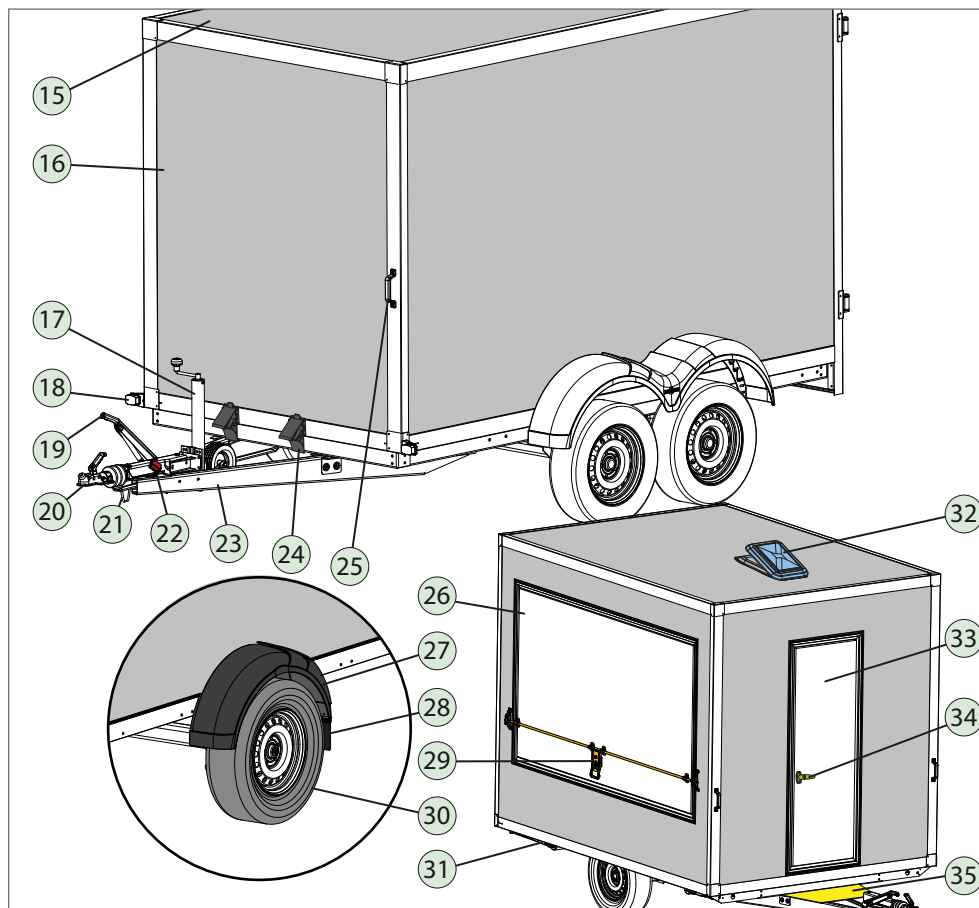

Front view

2.6 Components

1. Position light
2. Rain guard
3. Hinge (stainless steel)
4. Espagnolette
5. Espagnolette lock (vertical)
6. Double-wing door
7. Tail light, combined with triangular reflector, indicator, brake light, rear fog light and potentially reversing light and position lamp
8. Underride protection
9. Hook
10. Wood/aluminium cover
11. Ramp front edge
12. Espagnolette lock (horizontal)
13. Ramp wall
14. Gas strut
15. Roof
16. Front wall
17. Jockey wheel
18. Front reflector / white reflector or front position lamp
19. Hand brake lever
20. Ball coupling
21. Drawbar support
22. Parking socket electric systems / plug holder
23. V drawbar
24. Wheel chock
25. Handle
26. Sales hatch
27. Mudguard
28. Spray flap
29. Espagnolette lock (horizontal)
30. Wheel (tyre)
31. Support
32. Skylight
33. Access door
34. Rotary handle
35. Step



Accessories / extensions are separately explained in the partial description below and in the operating instruction manual "Trailers up to 3.5 t" (General Points - Part 1).

2.7 Plywood box

2.7.1 Single-axle trailer with ramp wall + cover



2.7.2 Single-axle



2.7.3 Tandem



2.8 Sandwich box

2.8.1 Single-axle flatbed trailer



2.8.2 Tandem flatbed trailer



2.8.3 Tandem wheels-in trailer



2.9 Sandwich box, PurFerro

2.9.1 Single-axle flatbed trailer



2.9.2 Tandem flatbed trailer



2.10 Cool Trailer (down to 6 °C)

2.10.1 Single-axle



2.10.2 Tandem



Cover for refrigerating unit



Safety step



Light switch for interior lighting

2.11 Freezer box trailers (down to -18 °C)

2.11.1 Freezer box trailer



Refrigerating unit down to 0 °C / -18 °C



Cover for refrigerating unit



Access door at the side



Divided body / inner door



Ceiling-rail



Meat hook



Power generator on the drawbar



Safety step

2.12 Sales box trailers

2.12.1 Basic model



2.12.2 Standard fittings



Roof vent



Sales hatch on the rear



Gas bottle compartment



Sales counter

2.13 Optional accessories

2.13.1 General



Cash drawer

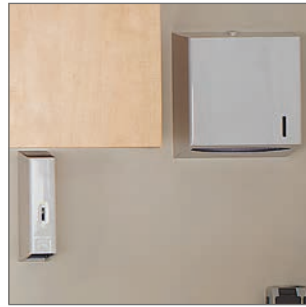

Hygiene package



Spare wheel on front wall



Spare wheel on drawbar



Double basin



Cover for base cabinet



Motorcycle stand

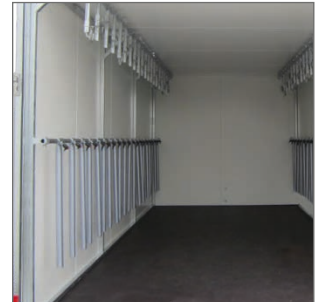

Bicycle stand



230 volt main voltage connector

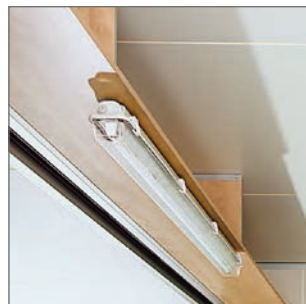

Linear luminaire + switch



Ladder



Advertising panel frame



Twin socket



Distributor box + FI + fuses



Floor insulation

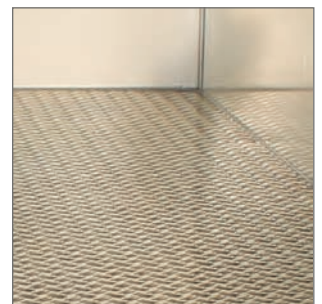

Aluminium tread plate



Scuff protection strip



Cable winch + flap

2.13.2 Electric systems



Adapter 7-/13-pin



Adapter cable 2.5 m



Linear luminaire



Interior light

2.13.3 Load securing



Barred tie rail



Slotted tie rail



Lashing angles



Folding rings

2.13.4 Body



Top flap + double-wing door



Top flap + ramp wall



Sales hatch on the side



Sales hatch on the rear



Two sales hatches



Double-wing door on the side



Access door on the right



Access door at the front



Ramp wall as a revolving door



Ramp wall

2.13.5 Connection



Roller shutter on the side

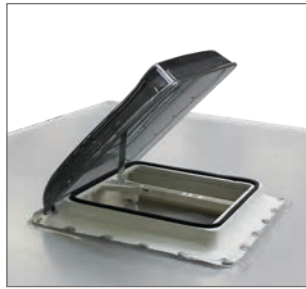

Roof vent



HV drawbar with ball head coupling



DIN towing eye for drawbar



Window



Sliding window

2.13.6 Supports



Side vent



Sortimo side vent



Prop stands



Corner legs



Flap



Omnistep



Telescopic prop stands with crank handle



Telescopic prop stands, fixed



Folding step



Step



Telescopic prop stands, interchangeable

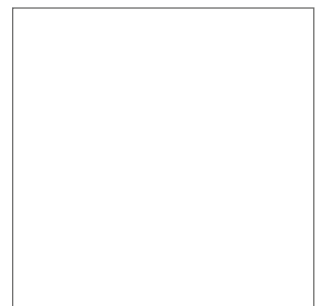

2.14 Special versions

2.14.1 Four-axle



2.14.4 Special customised versions



2.14.2 Turntable trailer



2.14.5 SENKO with box body



2.14.3 Bicycle carrier



2.14.6 HKT kneeling trailer with box body



Please refer to the respective operating instruction manual for the SENKO and kneeling trailer models.

2.14.7 Sales trailer with stairs



2.14.10 Two-storey



2.14.8 Sales trailer with platform



2.14.11 Customised foiling / lettering



2.14.9 Ramp wall with platform



2.14.12 Slanted body



2.14.13 Aluminium body with cover + ramp wall



2.14.16 Plexiglass windows



2.14.14 Vehicle transport



2.14.17 Divided body



2.14.15 Sales trailer with sliding glass wall



2.14.18 Promotion version with roller shutter



3 Intended use

3.1 Box trailers in general

- Box trailer with a closed body, optionally with a double-wing door, ramp wall or wood/aluminium cover, for transporting goods protected from the weather.
- The body is protected against theft by means of a lockable closing mechanism.
- Loading / unloading and transporting of materials and goods as fixed / linked load units.
- Transporting of load units, with the exception of hazardous goods, e.g. explosive, chemical or liquid materials.
- Form and force-fitting load securing by means of tie rails and locking bars in the body as well as tie-down rings on the cargo bed.

3.2 Refrigerated box trailers

- Cool Trailer intended for the transport of goods, e.g., beverages, down to a cooling temperature of + 6 °C.
- Freezer box trailer for the transport of perishable goods, such as food, with a cooling temperature of + 10 °C to - 18 °C.
- Possibility of emergency unlocking from the interior of the box.
- Power generator on the drawbar to operate the refrigerating unit.

3.3 Sales box trailers

- Sales box trailer with sales hatch is available as a basic model or with fittings.
- Geared towards mobile sales activities, e.g., at markets.
- With special interior equipment, such as sales counter, double basin or gas bottle compartment for catering trade.

3.4 Special versions

- Box trailer as a special version for a wide range of applications, such as promotional tours, bicycle transport, car transport and advertising, with appropriate equipment.
- Box trailer with lowerable chassis (SENKO, HKT kneeling trailer) to facilitate driving onto the cargo bed.

4 Foreseeable misuse

4.1 Box trailers in general

- Transport of persons / animals.
- Driving with doors / flaps not closed / locked.
- Driving with support devices not retracted / secured.
- Opening the double-wing door / access door without securing it with a door holder.
- Walking on / loading the cargo bed (with single-axle box trailers) without coupling or supporting the trailer.
- Operating the trailer with foreign matter on the roof (snow, ice, branches, etc.).
- Walking on the box body roof.

4.2 Refrigerated box trailers

- Transport of non pre-cooled goods in a non pre-cooled refrigerated box trailer.
- Fully loading the trailer without complying with the requisite distance for air circulation.
- Shutting persons / live animals in the interior of the box.
- Failure to comply with the operating / maintenance / service instructions of the refrigerating unit manufacturer.

4.3 Sales box trailers

- Driving with unsecured interior equipment, such as furniture, sliding glazing, doors, flaps, counter and gas/electrical appliances.
- Operating a sales box trailer without complying with the requisite official regulations, e.g., trade, hygiene and workplace regulations.
- Parking and entering a sales trailer on uneven ground without adequate support.
- Opening the sales hatch without securing it (e.g., against high winds).
- Overloading the power supply of the sales trailer by running too many electrical devices. (Observe current consumption of the electrical appliances used)
- Failure to comply with the operating / maintenance / service instructions of the respective manufacturer.
- Operating gas appliances with an inadequate air supply.
- Operating gas appliances which have not been inspected as required by law.

4.4 Special versions

- Driving special versions with special equipment, e.g., bicycle, car, stairway, advertising panel, inadequately secured.

5 General Safety Instructions



Observe the other general safety recommendations in the operating instruction manual, "Trailers up to 3.5 to" (General Points - Part 1).



Risk of suffocation!

People can suffocate in the closed box body.



WARNING



Trapped in the box body

People can suffocate through lack of oxygen if they are trapped in the box body - risk of suffocation!

- ▶ Before closing the doors / flaps, ensure that nobody is in the box body.

Objects on the roof

Materials such as snow / ice can be thrown on the road during the journey - accident risk!

- ▶ Remove ice and snow from the roof in general and before driving off.
- ▶ Check that there are no objects on the roof before driving off.



Snow on the roof



Climbing on the roof is absolutely prohibited!
The operator accepts full responsibility if this is disregarded.



WARNING



Keep off the roof!

The structural stability of the roof of the box trailer is insufficient for supporting a person. They can slip and fall - falling hazard!

- ▶ The roof may only be accessed in exceptional cases and with additional protection against falling.
- ▶ Use approved / tested access aids, e.g., a stable step ladder, for cleaning purposes.

NOTICE

Open windows / flaps

Open windows / flaps could be damaged by strong wind / gusts of wind during the journey.

- ▶ Water can seep into the trailer interior in the event of rain / snow.
- ▶ Close the windows / flaps during strong wind / gusts of wind / rain / snow.



CAUTION



Folding ramp wall

After unlocking, the ramp wall can fall down uncontrollably, e.g., from load pressure - impact risk!
This can result in feet being crushed.

- ▶ Stand to the side when unlocking the ramp wall.
- ▶ Relieve the load pressure beforehand if necessary.
- ▶ Allow the ramp wall to fall to the floor if the as struts are defective.
Never try to stop it.

- ▶  Keep your feet away from the area around the ramp wall.

- ▶  Keep people away from the area around the ramp wall during unfolding.

- ▶ Use  .



Swivelling door

After unlocking, the door can swivel uncontrollably, e.g., by load pressure or gust of wind - risk of impact!

- ▶ Ensure that nobody enters the swivel area.
- ▶ Unlock the door carefully and press against it if necessary.
- ▶ Relieve the load pressure beforehand if necessary.
- ▶ After opening the door, secure it with the door holder.



Low body height!

You can bump your head when entering the cargo bed - risk of impact!

- ▶ Walk carefully onto the cargo bed - do not jump up and down.



Walking on the mudguards

You can fall if you walk on the mudguards, since the plastic mudguard gives way.

- ▶  Do not climb on the mudguards.

- ▶ If necessary, use a stable access aid, e.g., a ladder or stool, to operate the cover.

- ▶ If necessary, use the access aids, e.g., steps or folding step, fitted to the trailer.

6 Loading and Unloading

6.1 Load distribution



Before loading, check the max. load capacity that you are able to transport with your trailer.

Check that the max. permissible body dimensions of your trailer are not exceeded.

The load distribution works directly on the road handling of the towing vehicle tension.

NOTICE

Poor / one-sided load distribution of the goods

Strongly uneven / point load distribution can lead to over-stressing and damage to the trailer components.

- ▶ Before loading your trailer, check which load objects are the heaviest.
- ▶ Position the heaviest objects centrally on the cargo bed and in the area of the axles.
- ▶ Distribute the goods evenly over the cargo bed - Avoid point / one-sided load distribution.

Correct load distribution

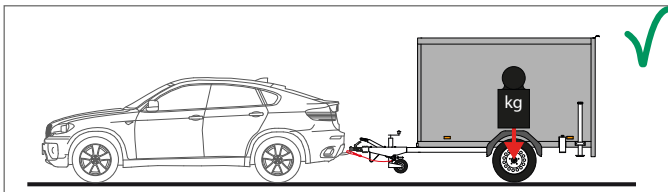

Load in axle area

The trailer and the towing vehicle are stable with all wheels on the ground.

Incorrect load distribution

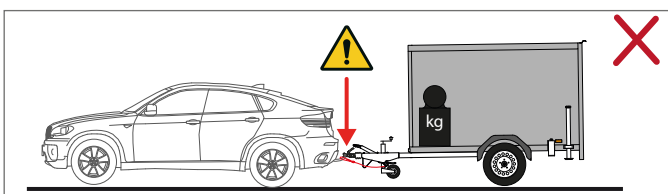

Load too far forward (toward motor vehicle)

The trailer tilts forwards; the towing vehicle tilts backwards = the max. drawbar load has been exceeded.

Incorrect load distribution

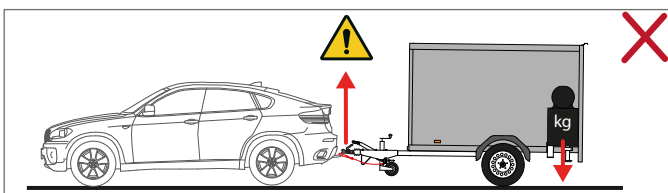

Load too far backwards (toward motor vehicle)

The trailer tilts backwards; the towing vehicle tilts forwards = the drawbar load is too low or is negative.

6.2 Load securing



For relevant safety information for load securing, refer to the section "General load securing" in the operating instruction manual "Trailers up to 3.5 to - General part 1".



WARNING

Unsecured load!

The load can be thrown around during the journey. The trailer may start to lurch - accident risk!

- ▶ Make sure that the load is secured by form and force-fitting before driving off.
- ▶ If required, have tie-down points retrofitted.

6.2.1 Tie-down points



Tie-down points on the cargo bed

1. Cargo bed
2. Tie-down point

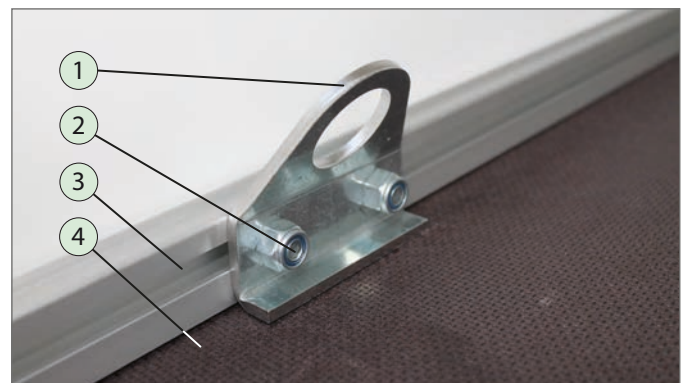

Lashing angle in detail

1. Lashing angle
2. Screw connection
3. Tie rail
4. Cargo bed

If required, the lashing angles can be placed at any position along the tie rail.

- ▶ Undo the screw connection.
- ▶ Position the lashing angle.
- ▶ Tighten up the screw connection.

6.2.2 Slotted tie rail with fittings

Functional explanation

- The load can be secured in the slotted tie rail with a locking bar and insertable fittings.
- The fittings can be individually positioned.
- The max. permissible tie-down forces are stated on the fittings.



Tie-down ring recessed in tie-down groove (optional)

1. Tie-down ring
2. Cargo bed
3. Tie-down groove

As an option, additional tie-down rings can be fitted to the cargo bed.

Note the specifications for the maximum permissible lashing forces.



Sticker for tie-down force

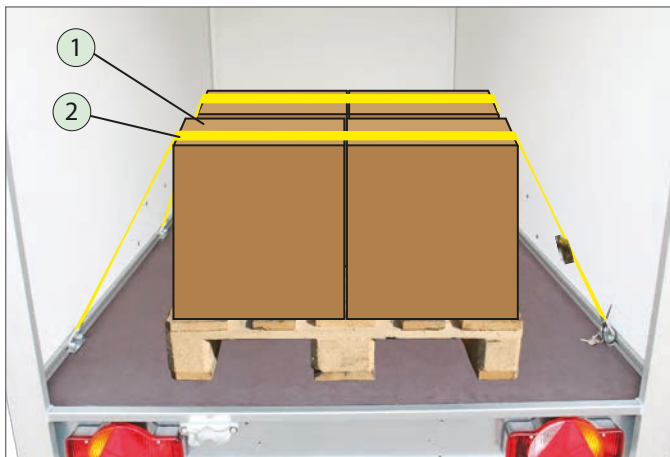

Correct load securing (example)

1. Loading unit
2. Lashing strap

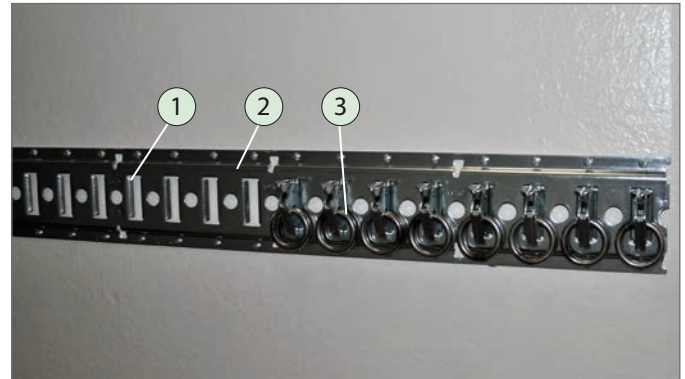

Slotted tie rail with fittings

1. Slot
2. Slotted tie rail
3. Fitting

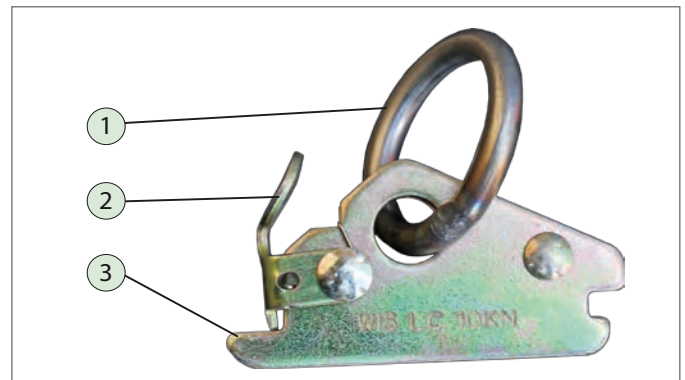

Fitting

1. Tie-down ring
2. Strap
3. Anchoring

Positioning fitting

- ▶ Position the fittings along the slotted tie rail.
 - ▶ Press on the strap and, at the same time, place the fitting into the slot of the rail.
 - ▶ Check that the fitting has snapped into the slotted tie rail.
- Goods can be tied down on the fittings.

6.2.3 Combined anchor rail



Leave unused locking bars in the combined anchor rail during the journey.



Load securing in the box body

1. Combined anchor tie rail (side, front end)
2. Locking bar

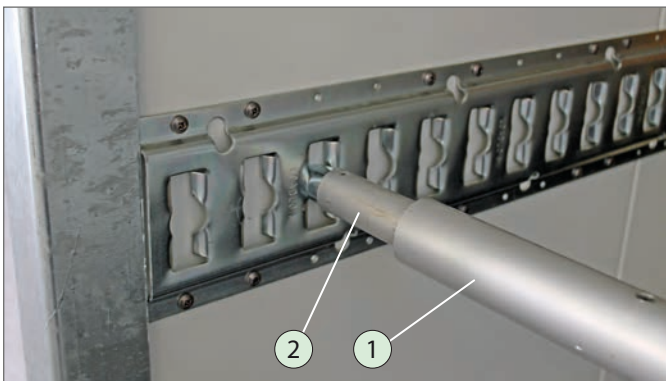

Locking bar, bar end

1. Bar end, insertable
2. Locking bar

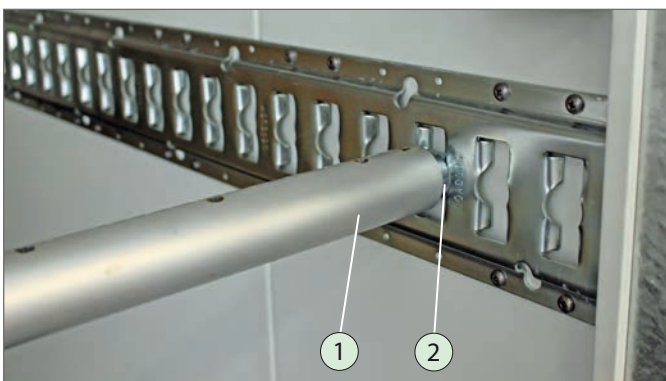

Locking bar, bar end

1. Locking bar
2. End journal

Locking bar

Functional explanation

- The locking bars are used for form-fitting load securing in conjunction with tie rails.
- The locking bars are telescopic and have a spring inside.



CAUTION



Inserting the locking bar

You can crush your hands between the beam and anchor rail when inserting the locking bar.

- ▶ Hold the locking bar in the middle.
- ▶ Keep your hands / fingers away from the anchor rail when positioning the locking bar.

Removing the locking bar

You and others could be struck through the spring force when removing the locking bar.

- ▶ Remove the locking bar carefully - hold it firmly.
- ▶ Guide the locking bar upwards at an angle.

NOTICE

Damage to the inside wall

When handling the locking bar, the inner wall could be damaged through the spring force.

- ▶ Handle the locking bar carefully - hold it firmly.



Damaging the inner wall

Removing the locking bar

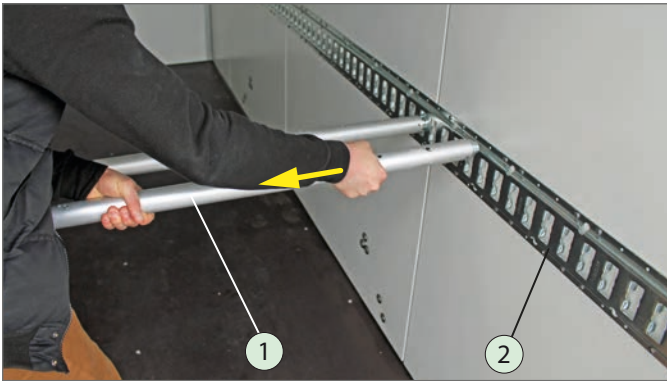

Releasing the locking bar

1. Locking bar, compressed
2. Tie rail

- ▶ Press the locking bar together so that the end journal emerges from the tie rail.
- ▶ Hold the locking bar firmly in this position.

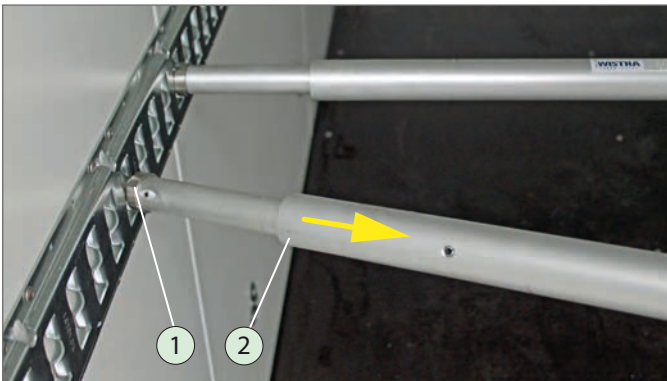

Removing the locking bar

1. End journal
2. Locking bar, relaxed

- ▶ Carefully guide the other end journal out of the tie rail.
- ▶ Swivel the locking bar slightly upwards or to the side so that it does not damage the interior walls.
- ▶ Place the locking bar horizontally in a location secure from damage - not in the danger area (work zone).

Inserting the locking bar

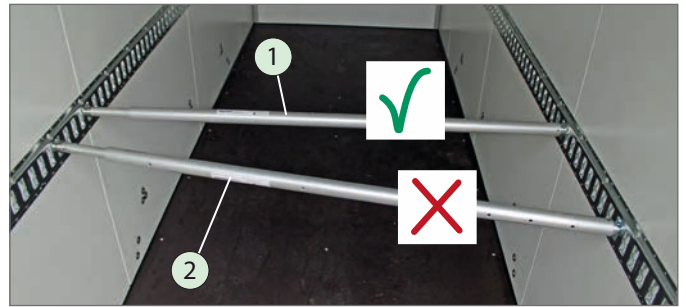

Inserting the locking bar

1. Locking bar, inserted flush
2. Locking bar, inserted at an angle



The loader / driver / vehicle owner and consignor are equally responsible for load securing.

- ▶ Check that the load can be properly secured before loading.
- ▶ Place the locking bar as close as possible to the load, so that there is as little space in between as possible.

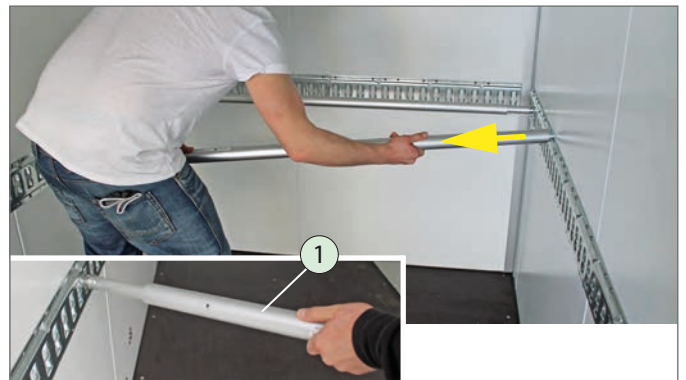

Positioning the locking bar

1. Locking bar, inserted on one side
 - ▶ Insert the end journal into the tie rail on one side.
 - ▶ Press the locking bar together.

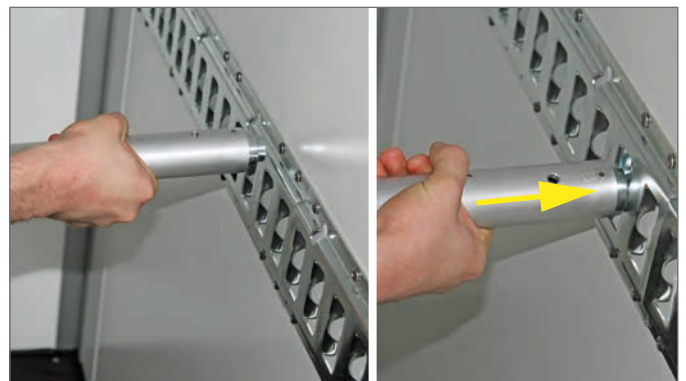

Securing the locking bar

- ▶ Insert the end journal into the tie rail.
- ▶ Ensure that the locking bar sits flush.

The locking bar has been positioned and secured.

6.2.4 Barred tie rail



Barred tie rail with inserted locking bar

1. Ramp wall
2. Barred tie rail
3. Locking bar

Handling the locking bar

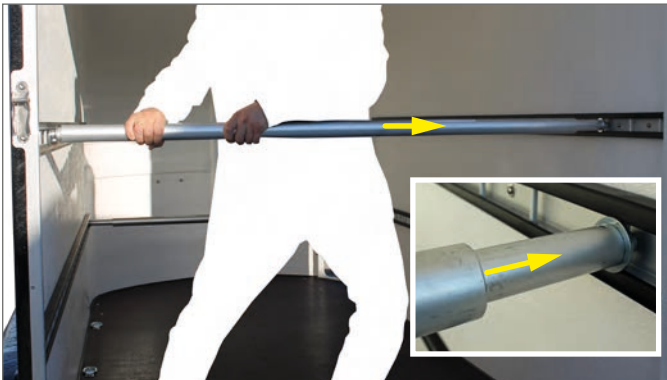

Removing the locking bar

- ▶ Press the locking bar together so that the end journal is disengaged from the tie rail.
- ▶ Carefully guide the other end journal out of the tie rail.
- ▶ Swivel the locking bar slightly upwards or to the side so that it does not damage the interior walls.
- ▶ Place the locking bar horizontally in a location secure from damage - not in the danger area (work zone).



Positioning the end journal

- ▶ Place the end journal on the bar.
 - ▶ Ensure that the locking bar sits flush.
- The locking bar has been positioned and secured.

6.3 Supports



The operation of the various supports is not explicitly described here!



Take note of the safety / warning instructions for operating the supports provided in the operating instruction manual "Trailers up to 3.5 to - General - Part 1."

Refer to the operating instruction manual, "Trailers up to 3.5 to - General - Part 1" for operation of the various supports.

6.3.1 Prop stands

Functional explanation

- The prop stands are mainly used in smaller single-axle and tandem box trailers.
- As an option, the prop stands are available loose or as fitted accessories.
- The prop stands can be fitted in the front and / or rear area of the chassis.



Prop stand in the driving position

- ▶ Raise the prop stands before driving off.
- ▶ Tighten up the handle.



Prop stand in the support position

- ▶ Lower and secure the prop stands for loading / unloading.
- ▶ Tighten up the handle.

6.3.2 Corner legs

Functional explanation

- The corner legs are fitted as standard in sales box trailers.
- The corner legs can also be used in other trailer types.
- The corner legs are fitted in the front and rear area of the chassis.
- The corner legs are operated with a supplied crank handle.



Corner leg in the driving position

- ▶ Raise and secure the corner legs before driving off.



Corner leg in the support position

- ▶ Lower and secure the corner legs for loading / unloading and for sales activities in the parking position.

6.3.3 Telescopic prop stands, fixed

Functional explanation

- The telescopic prop stands are mainly used in Cool Trailers and freezer box trailers.
- As an option, the telescopic prop stands are available as fitted accessories.
- The telescopic prop stands can be fitted in the front and rear area of the chassis.
- The telescopic prop stands are attached over their full length to a sturdy supporting tube under the chassis.



Telescopic prop stands in the driving position

- ▶ Raise and secure the telescopic prop stands before driving off.



Telescopic prop stands in the support position

- ▶ Lower and secure the telescopic prop stands for loading / unloading.



Attachment to the chassis

6.3.4 Telescopic prop stands, interchangeable

Functional explanation

- The telescopic prop stands are mainly used in Cool Trailers and freezer box trailers.
- As an option, the telescopic prop stands are available loose or as fitted accessories for each box trailer model.
- The telescopic prop stands can be fitted in the front and / or rear area of the chassis.



Telescopic prop stands in the driving position

- ▶ Raise the telescopic prop stands before driving off and secure them in the horizontal position.



Telescopic prop stands in the support position

- ▶ Lower and secure the telescopic prop stands for loading / unloading.

6.3.5 Telescopic prop stands, interchangeable (with fixed hand crank)

Functional explanation

- The telescopic prop stands are mainly used in Cool Trailers and freezer box trailers.
- As an option, the telescopic prop stands are available as fitted accessories.
- The telescopic prop stands can be fitted in the front and rear area of the chassis.



Telescopic prop stands in the driving position

- ▶ Raise the telescopic prop stands before driving off and secure them in the horizontal position.



Telescopic prop stands in the support position

- ▶ Lower and secure the telescopic prop stands for loading / unloading.

6.4 Door / double-wing door

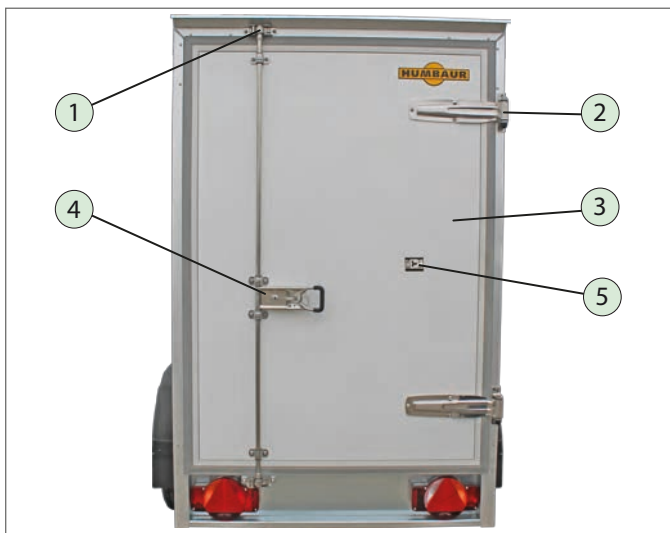

Rear view of door

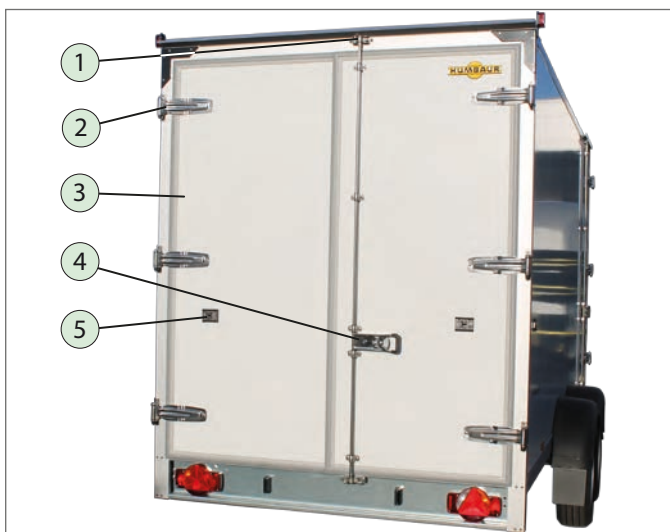

Rear view of double-wing door

1. Hook
2. Hinge
3. Double-wing door
4. Espagnolette lock
5. Door holder

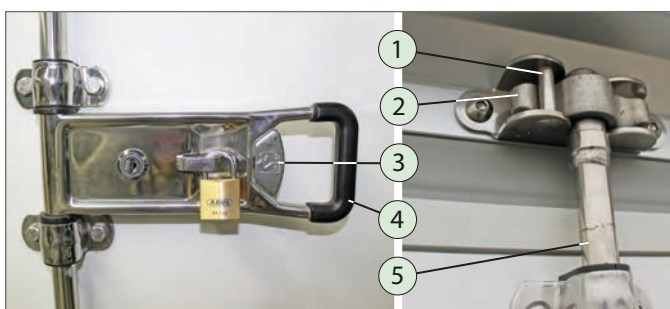

Espagnolette lock closed / secured

1. Locking bolt
2. Hook
3. Snap-lock
4. Handle
5. Espagnolette

Unlocking

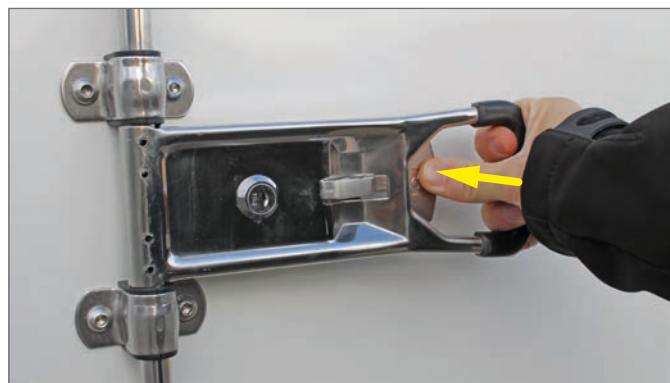

Unlocking the espagnolette lock

- ▶ Engage the snap lock.

Opening



Opening the espagnolette lock

- ▶ Pull the handle.
- The lock is released.
- ▶ Turn the handle so that the lock hooks move out of the lock pins at the top / bottom.
- The door / double-wing door is unlocked.



Opening the double-wing door

- ▶ Check that there is enough space available behind the vehicle for the door to open.
- ▶ Open the door / double-wing door completely

Secure with the door holder

NOTICE

Unsecured door / double-wing door

The door / double-wing door can be damaged by impact - material damage!

- ▶ After opening the door / double-wing door, secure it with the door holder.

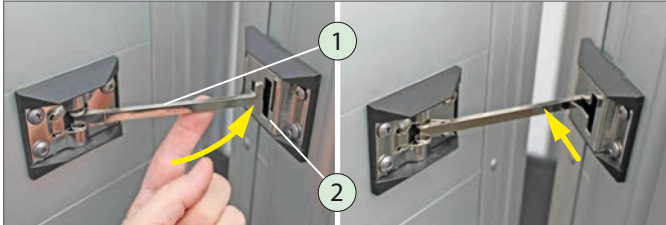

Locking the door holder

1. Locking lever
2. Locking sleeve

- ▶ Open the door until the locking lever can be inserted into the locking sleeve.
- ▶ Swivel the locking lever towards the locking sleeve.
- ▶ Press the locking lever inwards and up to the limit stop.

The door holder is hooked in.

The door / double-wing door is secured.



Double-wing door open, secured

Secure with support rope (optional)

NOTICE

Unhooking the support rope

Components of the trailer can be damaged by impact with the door - material damage!

- ▶ Hold the door firmly after release.
- ▶ Secure the door against slamming shut after opening.

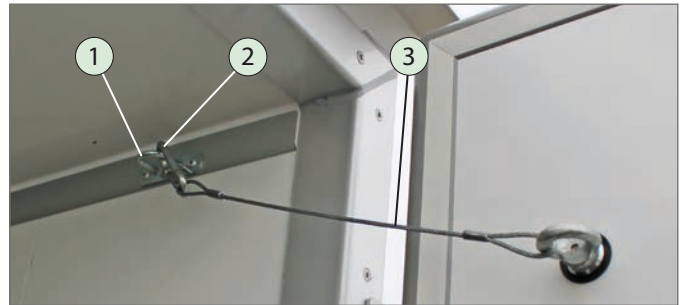

Support rope secured

1. Eyelet
2. Carabiner
3. Support rope



Door fully open, unsecured

- ▶ Insert the carabiner into the eyelet.

The door is secured against swivelling open.

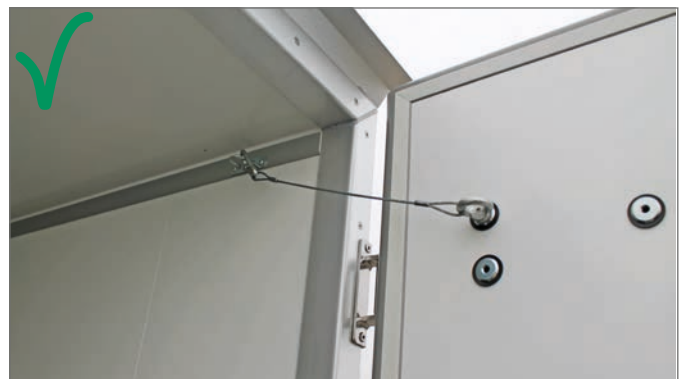

Door half-open, secured

Closing

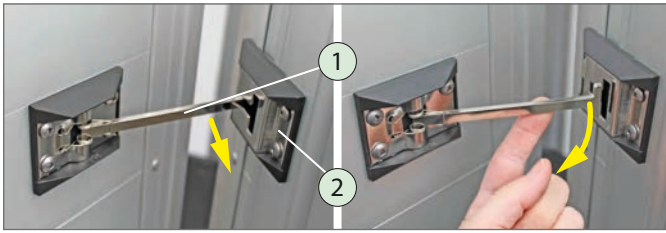

Unlocking the door holder

1. Locking lever
2. Locking sleeve

- ▶ Push the locking lever outwards.
- ▶ Slide the locking lever out of the locking sleeve.
- ▶ Release the locking lever.

The door holder is unlocked.

The door / double-wing door is unsecured.



Closing the double-wing door

- ▶ Close the double-wing door.
 - First close the left wing and then the right wing.



Locking hook

- ▶ Insert the locking hooks into the locking pins.



Closing the espagnolette lock

- ▶ Push the handle shut so that the hooks engage with the lock pins.

The lock is secured with a snap latch.



Door / double-wing door closed, secured

The door / double-wing door is secured against inadvertent opening while driving.



Espagnolette lock closed

- ▶ Also lock the lock with a key to prevent unauthorised access.

6.5 Freezer box door with emergency unlocking

Functional explanation

- The double-wing freezer box door is equipped with a function for emergency unlocking from the inside.
- A closed freezer box door can also be opened with the emergency unlocking lever.
-



Freezer box door with emergency unlocking

1. Freezer box door
2. Rotary lever
3. Door holder



Freezer box door opened and secured

Opening



Unlocking the freezer box door

- ▶ Unlock the cylinder lock with the key.
- ▶ Move the rotary lever to the horizontal position.



Opening the freezer box door

secured

- ▶ Check that there is enough space available behind the vehicle for the door to open.
- ▶ Fully open the right-hand door wing.
- ▶ Secure the door wing with the door holder. (see section Door / double-wing door - Secure with the door holder)

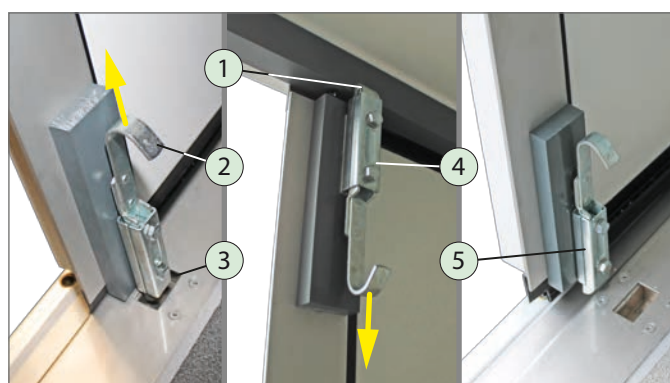

Unlocking the left-hand door wing

1. Bolt / latch
2. Bracket
3. Striking plate
4. Top snap-lock system
5. Bottom snap-lock system

- ▶ Release the top and bottom snap-lock system at the same time - pull the bracket. If required, use access aids or climb onto the cargo bed.

Emergency unlocking from the inside

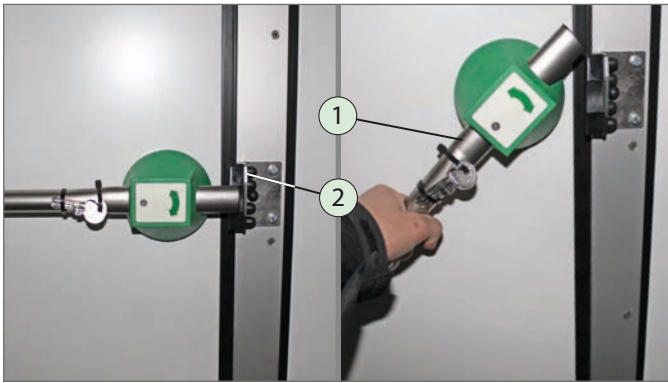

Emergency unlocking

1. Emergency unlocking lever
2. End stop

If you are locked in, emergency unlocking is possible from the inside. The emergency unlocking lever is provisioned with an illuminated sign that is visible in the dark.

► Move the emergency unlocking lever to the vertical position. The end stop is free. The door wing is unlocked.

Closing



The freezer box door must be locked with the key on the lock cylinder before driving off.

- Release the left-hand door wing with the door holder (See section Door / double-wing door – releasing the door holder).
- Close the left-hand door wing until the latches / bolts of the snap-lock systems engage.
- Release the right-hand door wing with the door holder.
- Fully close the right-hand door wing.
- Secure the right-hand door wing with the rotary lever.

6.5.1 Freezer box equipment (optional)

Functional explanation

- As an option, the Cool Trailer can be equipped in the factory with one or more ceiling-rails for meat hooks for hanging up chilled goods.
- The interior light is supplied with power via the refrigerating unit and can be activated by means of an optional door contact switch.

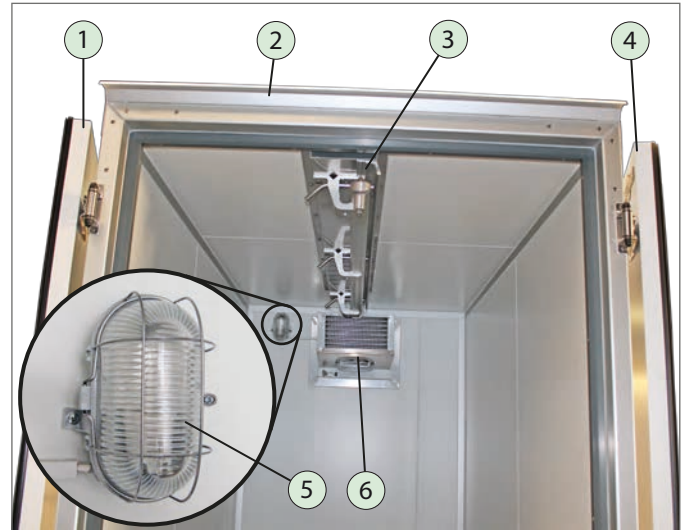

Refrigerated box trailer interior

1. Left-hand door wing
2. Rain guard
3. Ceiling-rail
4. Right-hand door wing
5. Interior light (230 V)
6. Refrigerating unit



The ceiling-rail may only be retrofitted in a specialist workshop.

6.6 Ramp wall

WARNING



Ramp wall overloaded The ramp wall may become deformed or break. The goods / vehicle to be loaded may tip over - risk of crushing!

- ▶ Drive up the ramp wall, e.g., with a pallet truck, evenly and slowly.
- ▶ If necessary, check the gross weight of the loading vehicle with the goods before starting.

Folding down the ramp wall

When unlocking and folding down the ramp wall, feet / hands / fingers can be crushed between the ramp wall and the ground!

- ▶ Hold onto the side of the ramp wall firmly with one hand.

- ▶ Use  .

CAUTION



Closing the ramp wall

Fingers / hands may be crushed in the area of the closing edges when closing the ramp wall.

- ▶ Carefully close the ramp wall - do not slam it.
- ▶ Keep your hands / fingers away from the area of the closing edges.

NOTICE

Overloading the ramp wall

The ramp wall can become deformed as a result of overloading! Components of the ramp wall, e.g., hinges can be damaged.

- ▶ Avoid point / one-sided loading when using the ramp wall.
- ▶ Distribute the load evenly over the ramp wall.

6.6.1 Espagnolette lock

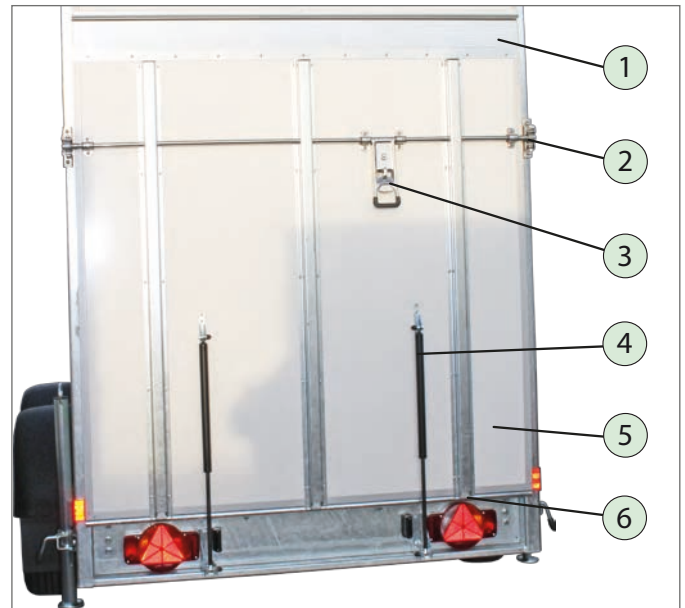

Ramp wall with espagnolette lock

1. Ramp front edge
2. Lock of espagnolette lock
3. Espagnolette lock
4. Gas strut
5. Ramp wall
6. Hinge arrangement

Opening



Unlocking / opening the ramp wall

- ▶ Unlock the handle with the key or remove the padlock.
- ▶ Release the espagnolette lock (See section Releasing the door / double-wing door).
- ▶ Press the handle shut so that it does not fall down onto the ground when folding down the ramp wall.
- ▶ Hold the side of the ramp wall and allow the ramp wall to descend slowly - do not let it fall.

The ramp wall is unlocked and folded down.

The gas struts support the operation of the ramp wall, so that it can be operated by a single person.

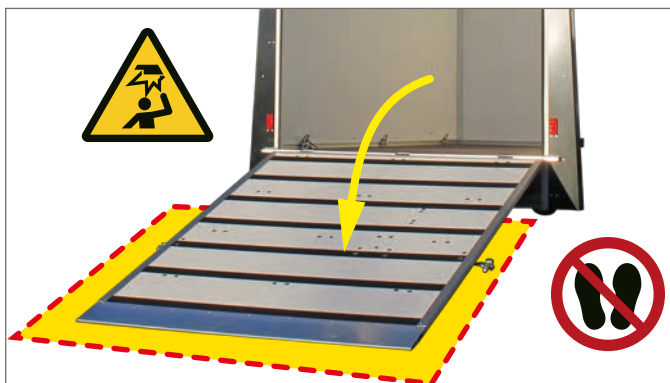

Folding down the ramp wall

- ! Make sure that your feet are not near the edge of the ramp wall.

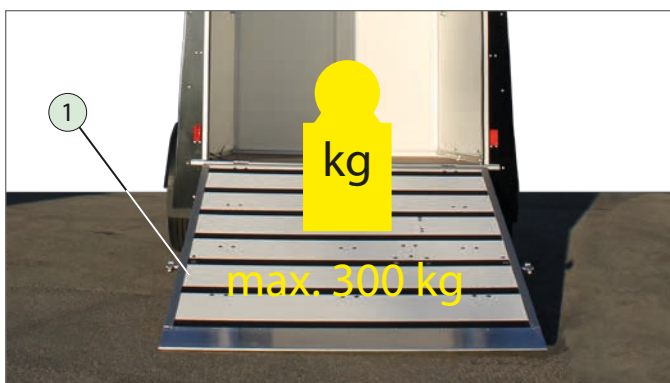

Ramp wall folded down

1. Ramp wall (max. 300 kg loading capacity)

The cargo bed can be loaded.

- ! Make sure that the trailer is secured so that it cannot roll away.

- ▶ Make sure that road traffic safety is not impaired when loading and unloading the trailer.
- ▶ If necessary, use additional signalling devices, e.g., signs, barriers.

Closing

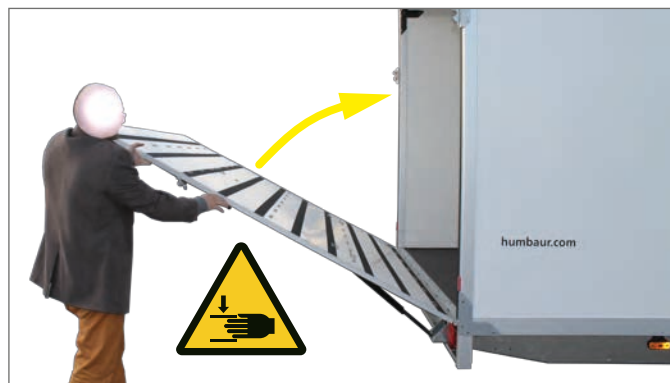

Closing the ramp wall

- ▶ Lift up the ramp wall from the side into the vertical position.
 - The gas struts will support you in the process.
- ▶ Unlock the espagnolette lock.
- ▶ Fold the ramp wall up fully.
- ▶ Lock the ramp wall with the espagnolette lock.



Ramp wall closed and secured

- ▶ Also lock the lock with a key to prevent unauthorised access.

The ramp wall is secured against automatic opening while driving.

6.6.2 Ramp wall with top flap



Ramp wall with top flap closed

1. Rain protection cover
2. Top flap
3. Ramp front edge
4. Ramp wall

Opening

- ▶ Open the ramp wall (See section Ramp wall - opening espagnolette lock).



Opening the top flap

- ▶ Pull on the operating strap. The top flap folds up automatically.

Closing



Closing the top flap

- ▶ Pull on the operating strap. The top flap folds down.
- ▶ Close the ramp wall. Ensure that the operating strap is on the inside (See section Closing the ramp wall).

6.6.3 Angle lever lock

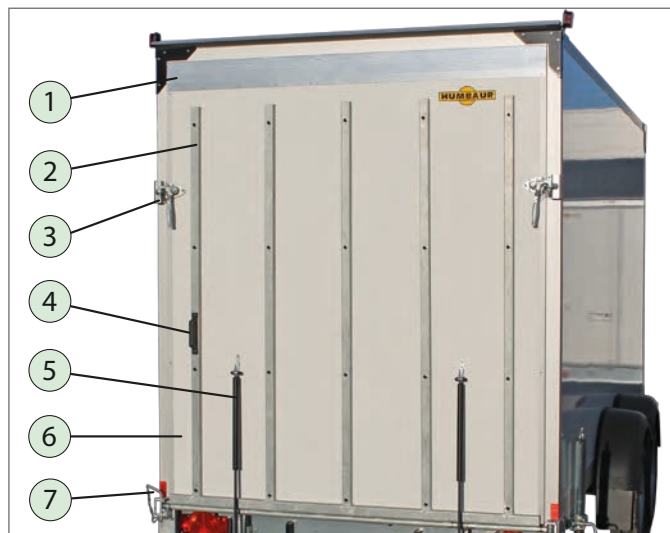

Ramp wall with angle lever lock

1. Ramp front edge
2. Support surface
3. Angle lever lock
4. Handle
5. Gas strut
6. Ramp wall
7. Revolving door lock



Angle lever lock released

1. Hook
2. Eyelet
3. Locking spring
4. Lever

- ▶ Position yourself on the side next to the ramp wall before unlocking the angle lever lock.

⚠ WARNING



Unsecured angle lever locks

The ramp wall could burst open while driving - accident risk!

- ▶ Check that all angle lever locks are secured with locking springs before driving off.

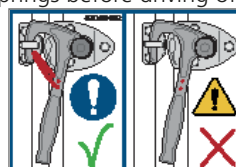

Unlocking locks



Angle lever lock closed

released

- ▶ Unlock the angle lever lock.
 - Push in the locking spring while turning the lever to the completely open position.

The hook is released.



Opening / tilting



Only place the ramp wall on completely level surfaces.



Lower ramp wall

- ▶ Use  .
- ▶ Grip the handle of the ramp wall.
- ▶ Slowly lower the ramp wall.
 - If necessary, push it downwards.
 - Make sure that your hands / feet are not under the edge of the ramp wall.

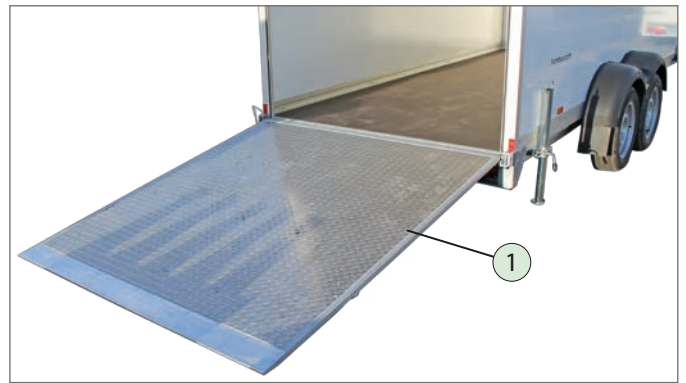

Ramp wall tilted

1. Ramp wall

Closing / securing

- ▶ Grip the middle of the lower edge of the ramp wall.
- ▶ Lift the ramp wall upwards - the gas struts will help you.
- ▶ Push the ramp wall completely shut.
- ▶ Hold onto the ramp wall firmly with one hand.
- ▶ Close the angle lever locks in turn.
 - The locking springs must engage.



Angle lever lock closed, secured

The ramp wall is secured against automatic opening while driving.

6.6.4 The ramp wall as a revolving door

Functional explanation

- The ramp wall can also be designed as a rotating door.

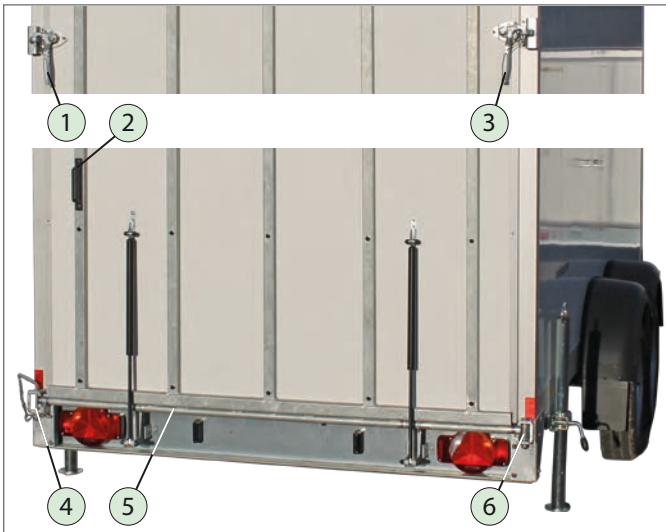

The ramp wall as a revolving door

- Left-hand angle lever lock
- Handle
- Right-hand angle lever lock
- Left-hand rotary lock
- Rods
- Bearing (hinge) on the right

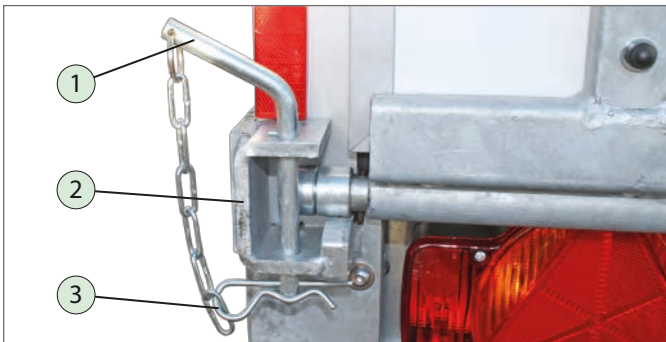

Revolving door lock

- Plug pins
- Revolving door lock
- Cotter pin

WARNING



Folding open the revolving door

After unlocking, the revolving door can fold open or fold down in an uncontrolled manner - impact / crushing risk!

- ▶ Stick to the sequence for unlocking the revolving door - see sticker.
- ▶ Never unlock both rotary lever locks.
- ▶ Hold the revolving door firmly with one hand.
- ▶  Keep people away from the area around the ramp wall during unfolding.

- ▶ Use  .

Unlocking the top lock



Take note of the attached sticker for operating the revolving door.

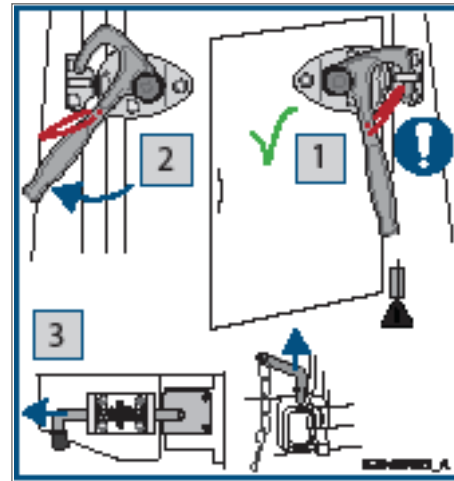

Opening the ramp wall as a revolving door



The right-hand angle lever lock remains closed (hinge side).

- ▶ Unlock the left-hand angle lever lock.

Unlocking the bottom lock

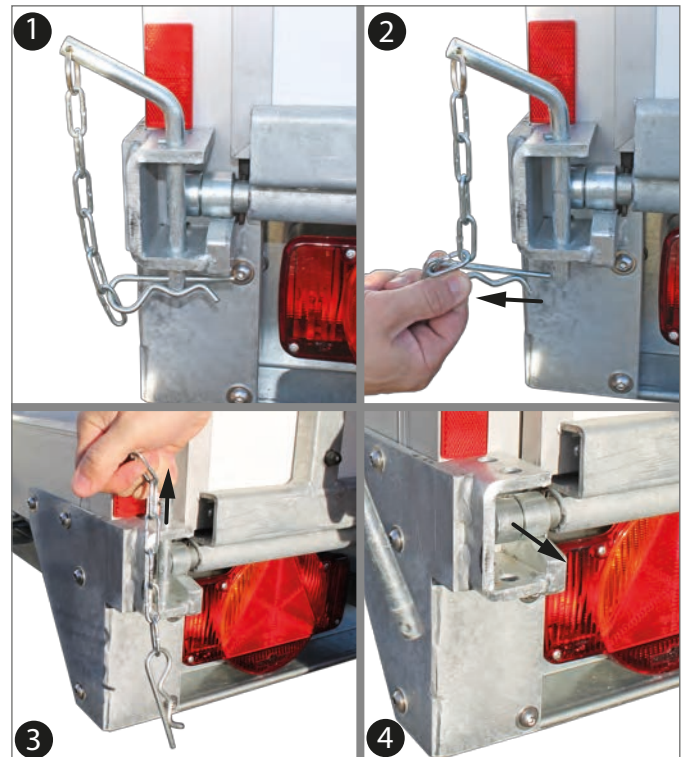

Opening the revolving door lock (left)

- ▶ Pull out the cotter pin on the plug pin. (2).
- ▶ Remove the plug pin from the revolving door lock. The revolving door is now unlocked at the bottom (3).
- ▶ Open the revolving door and insert the plug pin into the revolving door lock (4).

Opening / swivelling open



The revolving door does not have a door holder.
The revolving door may slam shut independently.

NOTICE

Overextending the revolving door!

The hinges of the ramp wall could be deformed.

- ▶ Only swivel the revolving door up to the limit stop or, if it does not have a limit stop, up to the level where no components can be damaged.



Opening the revolving door

- ▶ Grip the handle of the revolving door.
- ▶ Open the revolving door.



Revolving door open

- ▶ Hold the revolving door firmly with your hand and secure it against unintentional slamming.

Closing



CAUTION



Closing the revolving door

Fingers / hands may be crushed in the area of the closing edges if the revolving door slams shut.

- ▶ Carefully close the revolving door - do not slam it.
 - ▶ Keep your hands / fingers away from the area of the closing edges.
-
- ▶ Remove the plug pin from the revolving door lock.
 - ▶ Grip the handle of the revolving door.
 - ▶ Carefully swivel the revolving door until it is closed.

Locking the bottom lock

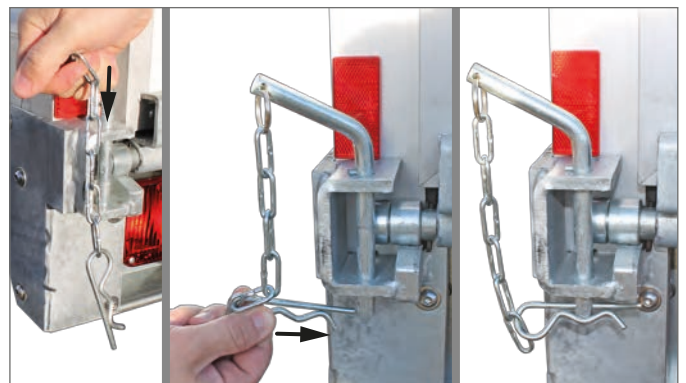

Locking the revolving door

- ▶ Push the revolving door completely shut.
- ▶ Insert the plug pin into the revolving door lock.
- ▶ Secure the plug pin with the cotter pin.

The revolving door is now locked at the bottom.

Locking the top lock

- ▶ Close the open angle lever lock.
- The locking spring must engage.



Revolving door locked top and bottom

The revolving door has been secured against unintentional opening while driving.

6.7 Ramp wall + wood/aluminium cover

Functional explanation

- The wood/aluminium cover can be locked with a key and thus protect your load against theft.
- The wood/aluminium cover is supported by gas struts for easier opening. The gas struts keep the cover in an open position.
- The wood/aluminium cover facilitates the loading / unloading of large bulky items, e.g., motorcycle transport.



Ramp wall + wood/aluminium cover

1. Ramp wall
2. Espagnolette lock
3. Lock
4. Handle
5. Pull strap
6. Cover
7. Gas strut
8. Side wall

WARNING



Driving with cover open / unlocked

The cover can spring open while driving and be torn off / deformed. The goods may be flung off. The trailer could lurch from side to side and be uncoupled from the towing vehicle.

- ▶ Do not drive with the cover open / half-open.
- ▶ Before driving off, check that the cover is properly closed and locked.

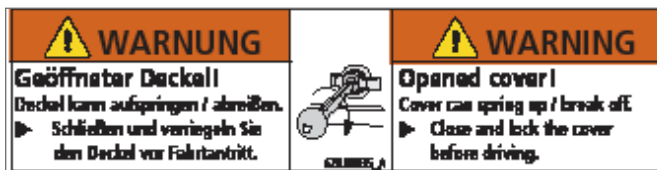

CAUTION



Operating the cover

You could crush your hands in the cover or bump your head while folding the cover down.

- ▶ Operate the cover carefully and support it. The gas struts help you to do this. - Do not allow the cover to fall shut on its own.
- ▶ Use the handle to operate the cover - keep your hands / fingers away from the closing edges.
- ▶ Use the pull strap to close the cover and hold it firmly by the handle.



Risk areas



Worn gas strut

If a gas strut is leaking / worn, the cover may fold down on its own and hit you.

- ▶ Secure the gas strut with the piston retainer.
- ▶ Have any faulty / worn gas struts replaced immediately by a specialised workshop.

NOTICE

Overloading the cover

The cover may become deformed or break.

- ▶ Limit the weight on the cover to a maximum of 60 kg.
- ▶ Do not climb onto the cover.

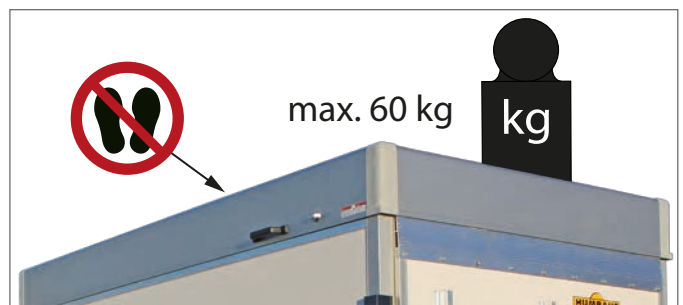

Unlocking

CAUTION



Operating height of the cover

You can fall if you climb on mudguards / wheels / the frame.

- ▶ Use a stable access aid, e.g., a ladder, stool or a permanently attached access aid, to operate the cover.

- ▶  Do not climb on the mudguards.

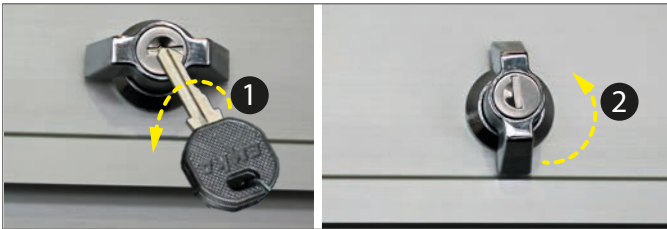

Releasing the lock

- ▶ Use the key to open the locks on both sides.

Opening



Cover released

- ▶ Turn the locks to the vertical position. The cover has now been released.
- ▶ Hold the cover firmly by the handle.



Opening the cover

- ▶ Pull out the pull strap.
- ▶ Hold the cover firmly by the pull strap.
- ▶ Allow the cover to open completely.
- The gas struts support the opening of the cover and hold it open in its final position.

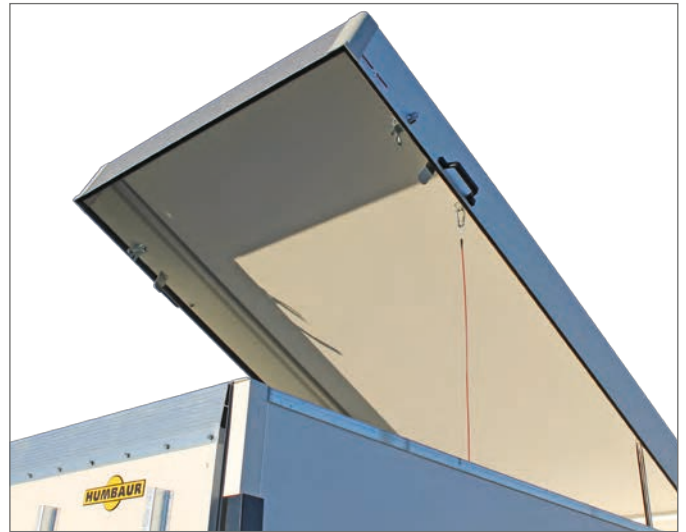

Cover open

- ▶ Release the ramp wall and fold it down (See section Opening ramp wall).

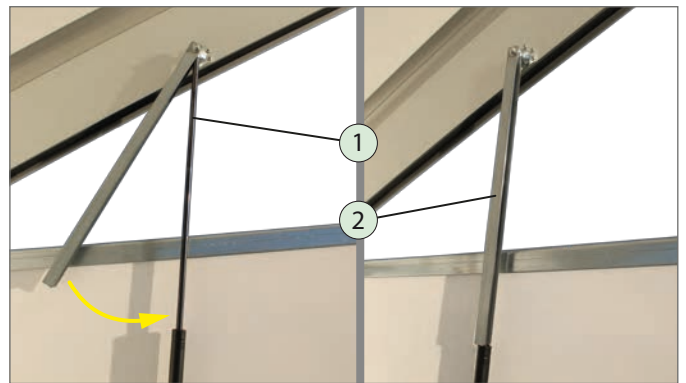

Securing the cover

1. Gas strut piston
2. Piston retainer

- ▶ Secure the gas strut with the piston retainer.

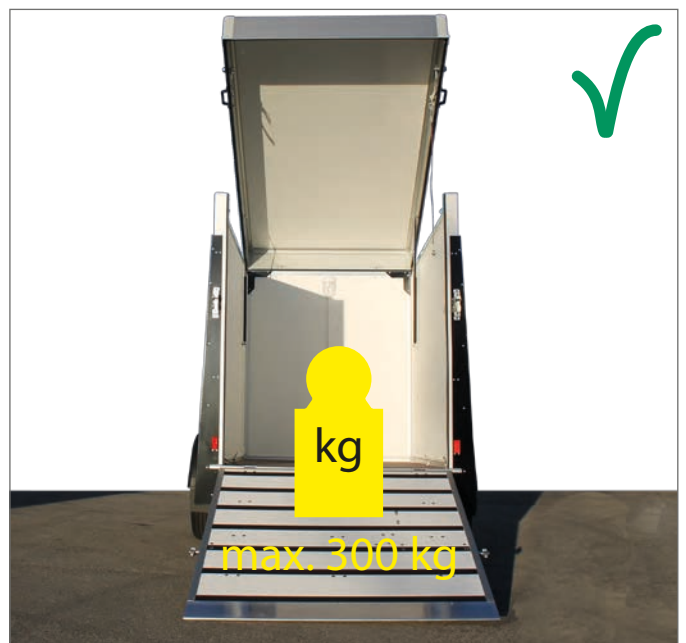

Cover open / secured

Closing

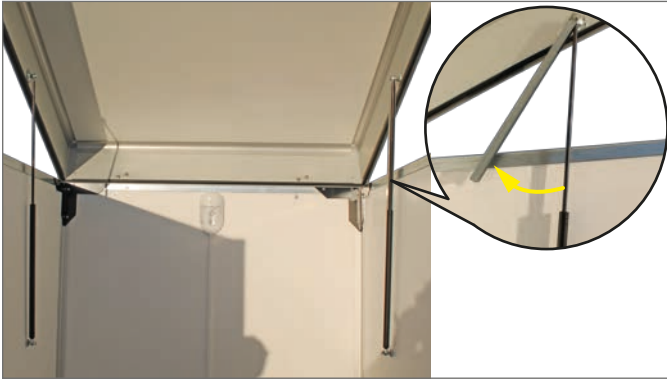

Releasing the gas strut

- ▶ Release the gas strut with the piston retainer.
- ▶ Close the ramp wall.



Closing the cover

- ▶ Take hold of the pull strap and pull the cover downwards until you can reach the handle.

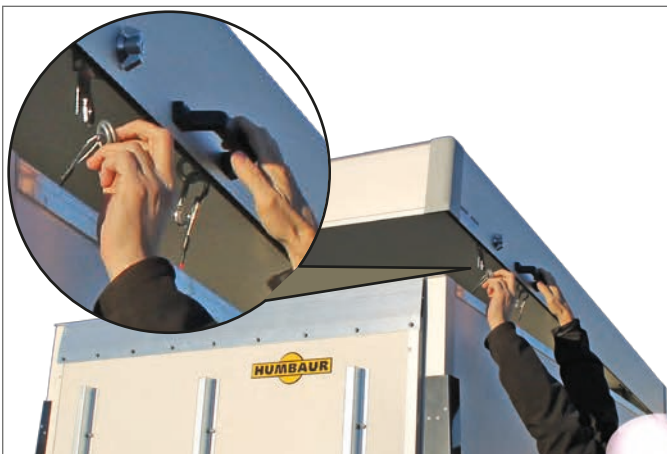

Stowing away the pull strap

- ▶ Hold the cover firmly with one hand.
- ▶ Stow away the pull strap in the interior of the box.
- ▶ Ensure that the lock is in the open position.
- ▶ Pull the cover completely shut.

Locking



Closing the cover

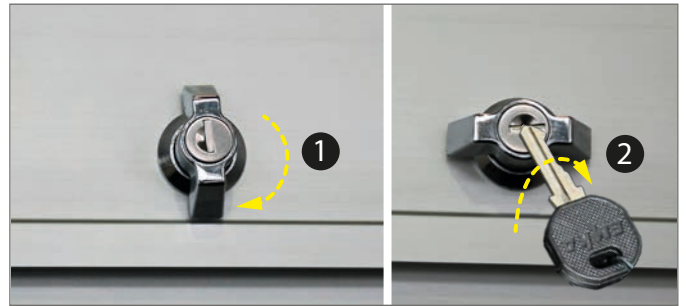

Locking the lock

- ▶ Turn the lock to the horizontal position. The cover is closed.
- ▶ Use the key to lock the lock. The cover is locked.



The goods must also be secured in a closed trailer.

- ▶ Secure the goods within the loading area.



Ramp wall + wood/aluminium cover closed / secured

6.8 Using the ramp wall

Using the ramp wall



Loading example 1

- ▶ Ensure that you do not overload the ramp wall (max. 300 kg).
- ▶ Slowly and carefully drive onto the ramp wall or slowly push the vehicle to be loaded upwards in a controlled manner.
- ▶ Make sure that the vehicle being loaded is in line with the ramp wall.

Walking on the ramp wall



Loading example 2

- ▶ Check that the piston retainer of the gas strut is secured before entering the trailer.
- ▶ Take particular care when walking on the ramp wall / cargo bed.

6.9 Sales hatch

⚠ WARNING



Driving with the sales hatch open / unlocked

The sales hatch can spring open while driving and be torn off / deformed. The goods could be thrown out. The trailer could lurch from side to side - accident risk!



- ▶ Before driving off, check that the sales hatch is completely closed and locked.

⚠ CAUTION



Operating the sales hatch

You could crush your hands or bump your head while folding the sales hatch down.

- ▶ Operate the sales hatch carefully.
- Do not allow the sales hatch to fall shut on its own.
- ▶  Keep people away from the area around the sales hatch when folding it down.
- ▶  It takes two people to operate large sales hatches.



Unsecured sales hatch

If a gas strut is leaking / worn, the sales hatch could fold down on its own - risk of impact!

- ▶ Secure the gas strut with the piston retainer.
- ▶ Have any faulty / worn gas struts replaced immediately by a specialised workshop.



Swivelling sales hatch

After unlocking, the sales hatch can swivel up uncontrollably - risk of impact!

- ▶ Ensure that nobody enters the swivel area.



Risk areas

6.9.1 Espagnolette lock

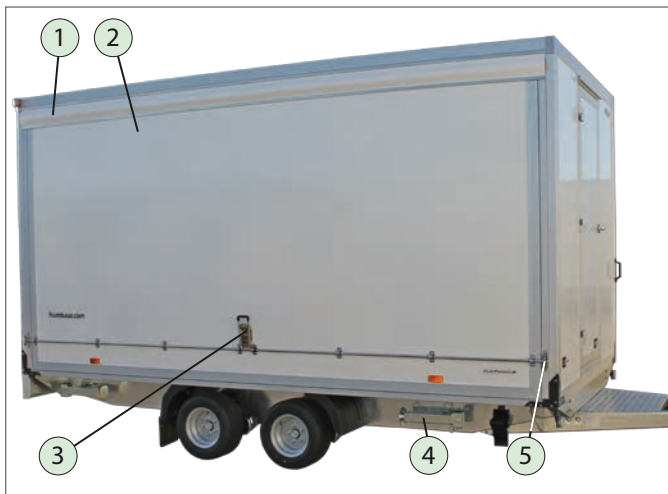

Sales hatch closed

1. Rain protection cover
2. Sales hatch
3. Espagnolette lock
4. Telescopic prop stand
5. Hook



Sales hatch open

1. Gas strut
2. Piston retainer

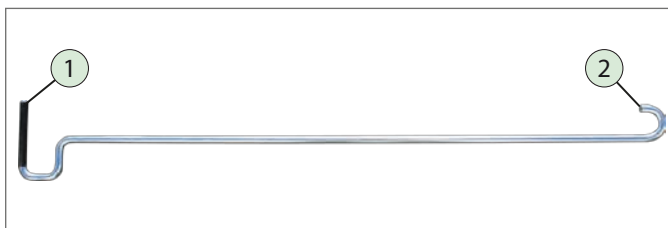

Operating rod

1. Handle
2. Hook

Opening

- ▶ Unlock the espagnolette lock.
(See section Door / double-wing door)

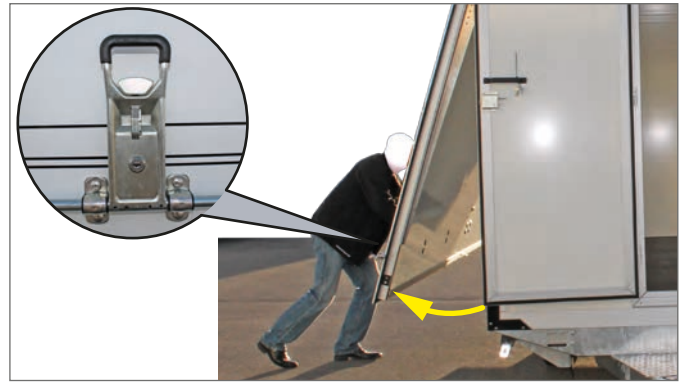

Opening the sales hatch

- ▶ Open the sales hatch and hold it firmly.
- ▶ Close the handle of the espagnolette lock.
- ▶ Pull / press the sales hatch upwards - the gas struts will support you in the process.

Securing

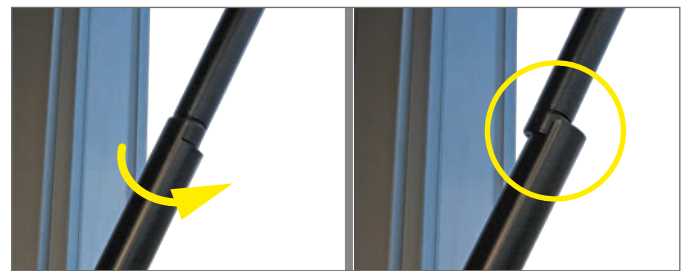

Gas strut released

secured

- ▶ Turn the piston retainer by 180°.
The sales hatch is secured against slamming shut on its own.

Closing

- ▶ Turn the piston retainer by 180°.

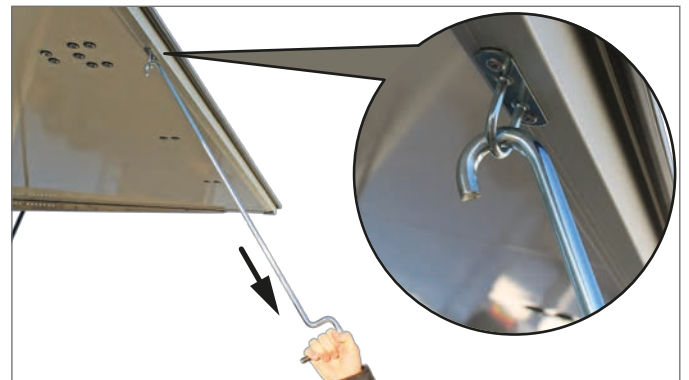

Closing the sales hatch

- ▶ Pull the sales hatch downwards using the operating rod with hook and hold it firmly.
- ▶ Remove the operating rod and open the espagnolette lock.
- ▶ Close and lock the sales hatch with the espagnolette lock.

6.9.2 Drive-rod lock

Functional explanation

- The sales hatch can be equipped with an internal drive-rod lock as an option.
- The drive-rod lock is in a recess on the outside and is flush with the outer wall.
- The sales hatch can be released and locked from the inside and outside.



Sales hatch with drive-rod lock, driving position

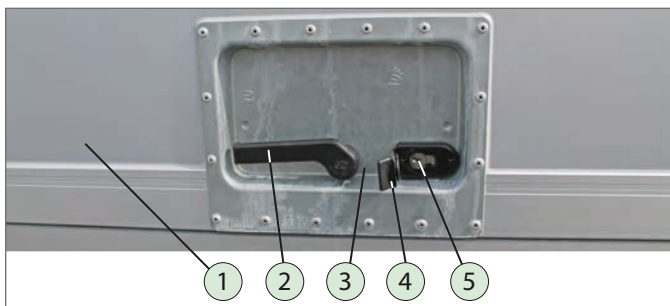

Detail of drive-rod lock, external view

1. Sales hatch
2. Handle
3. Recess
4. Covering cap
5. Cylinder lock

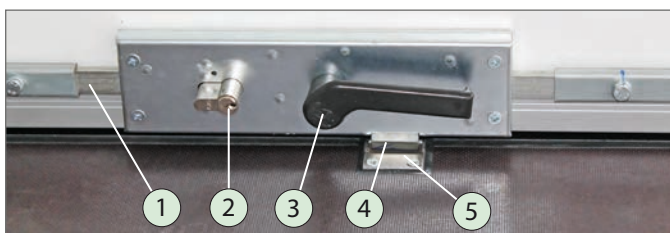

Detail of drive-rod lock, internal view

1. Drive rod
2. Cylinder lock
3. Handle
4. Bolt / latch
5. Striking plate

Opening



Unlocking the sales hatch

- ▶ Open up the covering cap of the cylinder lock.
- ▶ Unlock the cylinder lock with a key if required.
- ▶ Turn the handle upwards in a clockwise direction.

The sales hatch is unlocked.

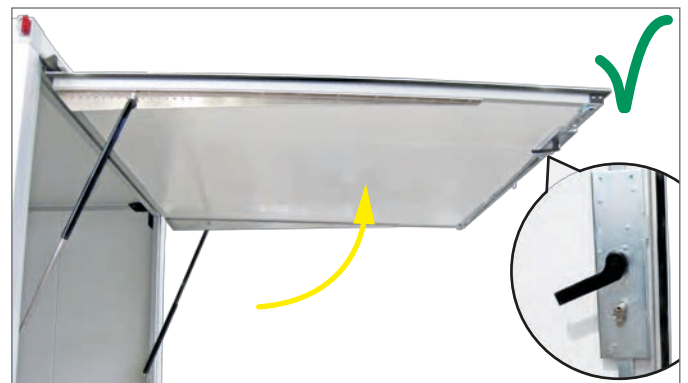

Sales hatch open

- ▶ Pull the sales hatch upwards.

The sales hatch is open.

Securing

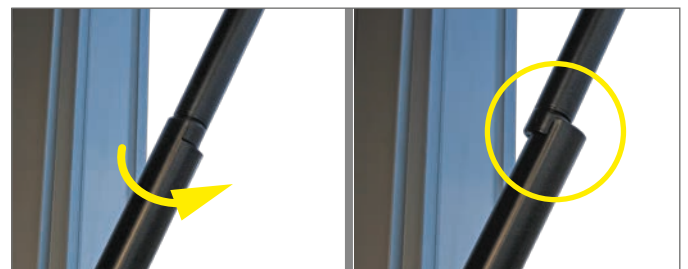

Gas strut released

secured

- ▶ Turn the piston retainer by 180°.
- The sales hatch is secured against slamming shut on its own.

Closing

- ▶ Turn the piston retainer by 180°.
- ▶ Fold down the sales hatch.
- ▶ Turn the handle in an anti-clockwise direction.
- ▶ Lock the cylinder lock with a key if required.
- ▶ Close the covering cap of the cylinder lock.

6.9.3 Flap lock (internal)



Sales hatch closed

1. Rain protection cover
2. Sales hatch
3. Corner legs



Sales hatch open

1. Flap lock (internal)
2. Gas strut
3. Piston retainer

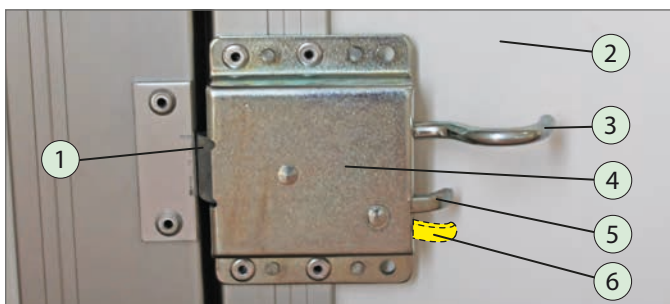

Flap lock from the inside

1. Latch / bolt
2. Sales hatch
3. Hook
4. Lock housing
5. Locking lever at top (open)
6. Locking lever at bottom (closed)

Opening

- ▶ Enter the trailer through the door.

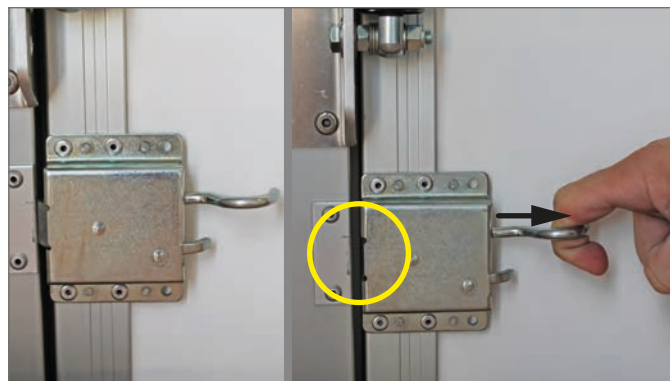

Release the flap lock

- ▶ Pull out the hooks on the right / left. The sales hatch is unlocked.

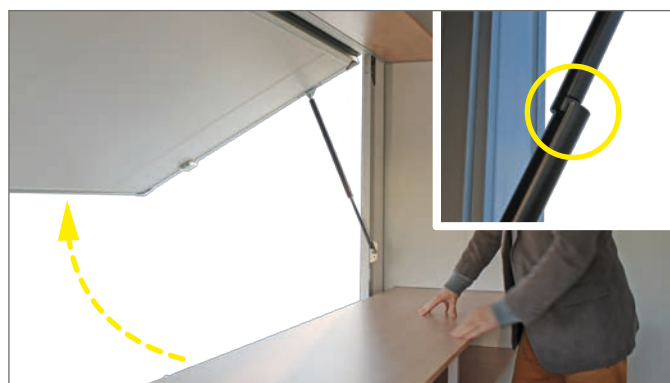

Opening the sales hatch

- ▶ Press the sales hatch upwards until it opens on its own. - The gas struts will support you in the process.

Securing

- ▶ Turn the piston retainer by 180°. The sales hatch is secured against slamming shut on its own.

Closing

- ▶ Turn the piston retainer by 180°.



Closing the sales hatch

- ▶ Carefully fold down the sales hatch until the latches / bolts of the flap locks engage.
- ▶ Lock the flap locks with the locking levers if required.

6.10 Sales counter (standard fittings)

Functional explanation

- The standard fittings only include the permanently installed sales counter with storage facilities.
- Additional interior fittings can be installed by the operator.

 The interior fittings must be properly secured by the operator before driving off!



External view of sales counter

1. Sales counter
2. Bag shelf (foldable)

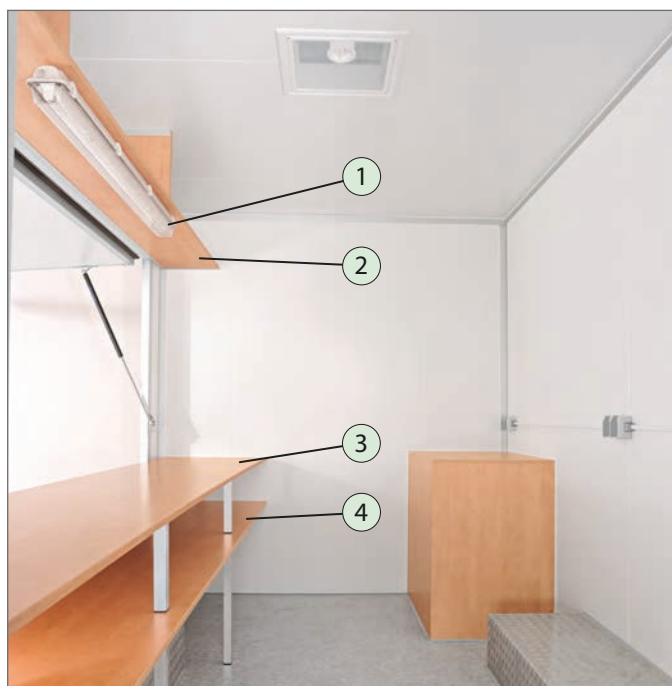

Internal view of sales counter

1. Linear luminaire
2. Storage space above sales hatch
3. Sales counter
4. Storage space

 **CAUTION**



Operating the bag shelf

Fingers could be crushed when closing the bag shelf.

- ▶ Keep your fingers away from the closing edge area.

6.10.1 Bag shelf

Fold down

- ▶ Open the sales hatch (see section on Sales hatch).

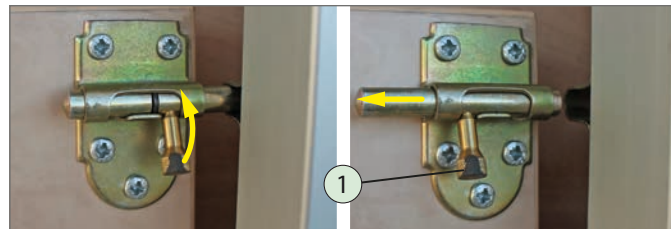

Bolt latched

released

1. Bolt

- ▶ Release the bolts on the right / left.

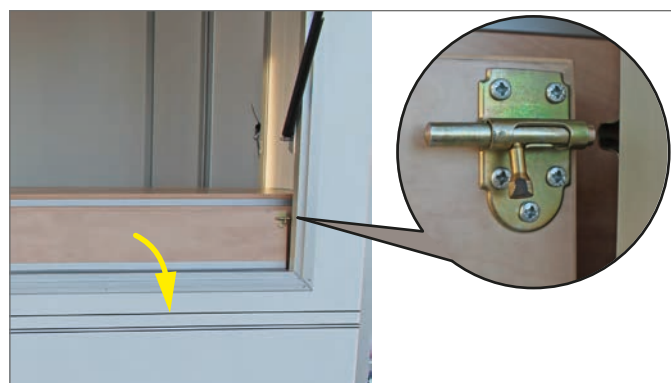

Folding down the bag shelf

- ▶ Fold down the bag shelf.

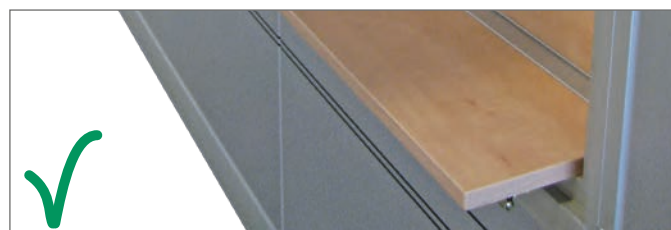

Bag shelf folded down

Closing

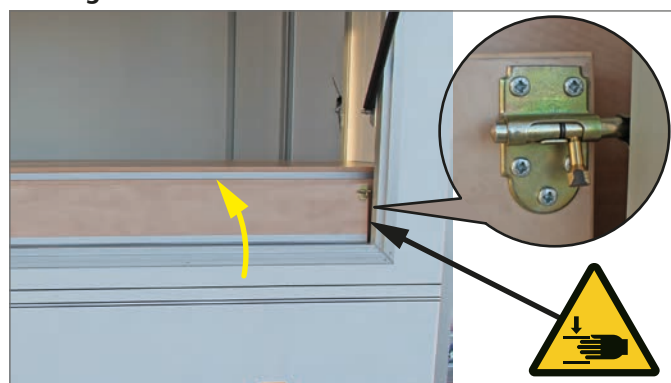

Bag shelf in the driving position

- ▶ Fold the bag shelf upwards.
 - ▶ Latch the bolts on the right / left.
- The bag shelf has been folded up and locked.

6.11 Roller shutter

Functional explanation

- The roller shutter can be used on the side or on the rear instead of a sales hatch.
- The roller shutter is provided with a full-length rod assembly for actuation and locking as well as with two cylinder locks for locking up.

CAUTION



Unsecured roller shutter

The roller shutter can open while driving.
The load could be thrown out - accident risk!

- ▶ Check that the roller shutter is closed and secured before driving off.



Roller shutter, closed

1. Rain guard
2. Roller shutter
3. Rods
4. Cylinder lock



Roller shutter, open

1. Pull strap

CAUTION



Operating the roller shutter

Fingers / hands can be crushed when closing the roller shutter.

- ▶ Keep your hands / fingers out of the closing edge area

Opening

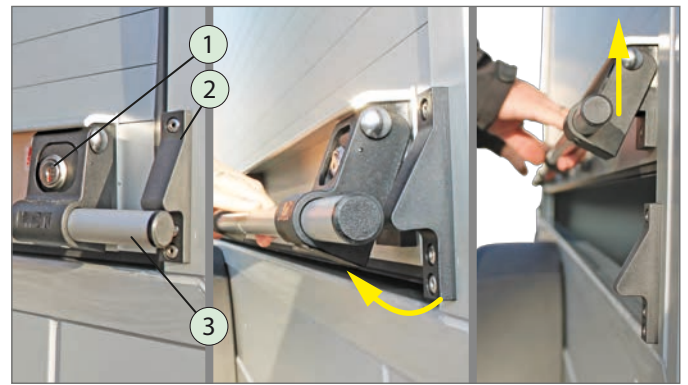

Opening the roller shutter

1. Cylinder lock
2. End stop
3. Rods

- ▶ Unlock the cylinder locks if required.
- ▶ Take the rod assembly in both hands and swivel it out of the end stops.
- ▶ Push the roller shutter upwards.

Roller shutter is open.

Closing



Closing the roller shutter

- ▶ Slowly pull the roller shutter downwards by means of the pull strap.
- ▶ Press the rod assembly down over the end stops.



Roller shutter closed / secured

- ▶ Lock the cylinder locks with a key if required.

6.12 Access door

CAUTION



Swivelling access door

After unlocking, the access door can swivel uncontrollably, e.g., as a result of load pressure / gusts of wind - risk of impact!

- ▶ Ensure that nobody enters the swivel area.
- ▶ After opening the access door, secure it with the door holder.

Access door with espagnolette lock

Functional explanation

- The access door is located on the side of the trailer in front of the axle.
- The access door can only be unlatched and locked from the outside.



Access door on the side, closed

1. Hook
2. Rods
3. Espagnolette lock
4. Door holder



Access door open, secured

- ▶ Opening / closing.
(See section Door / double-wing door)
- ▶ Secure the access door with the door holder
(See section Door / double-wing door - secure with the door holder).

Access door with drive-rod lock

Functional explanation

- The access door can be equipped with an internal drive-rod lock as an option.
- The drive-rod lock is in a recess on the outside and is flush with the outer wall.
- The access door can be unlatched and locked from the inside and outside.

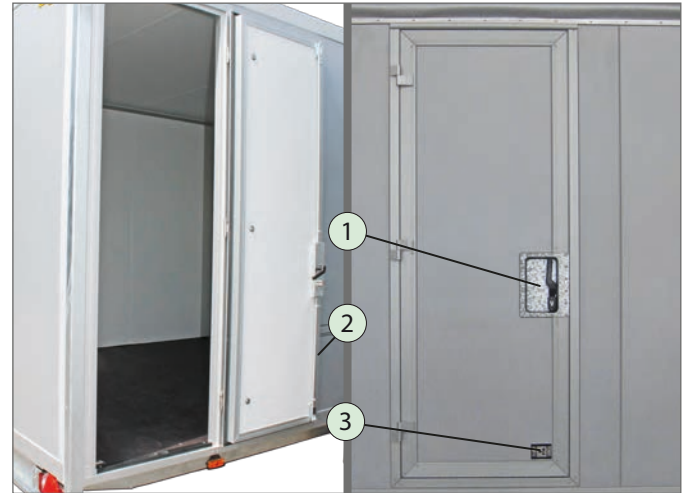

Access door closed

open

1. Drive-rod lock (in a recess)
2. Drive rod (internal)
3. Door holder

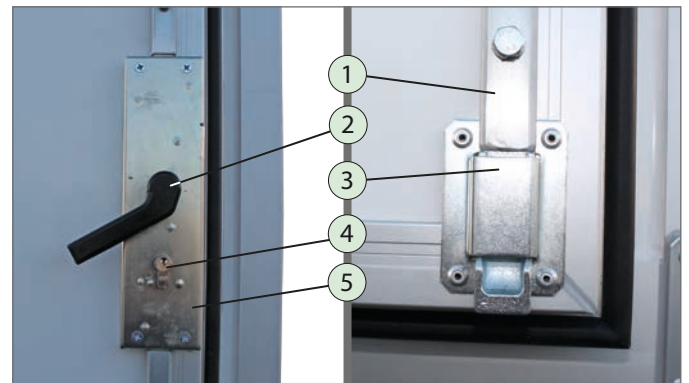

Handle inside

Drive-rod inside

1. Drive rod
2. Door handle
3. Drive rod guide
4. Cylinder lock
5. Lock housing

- ▶ Opening / closing
(See section Sales hatch - drive-rod lock).
- ▶ Secure the access door with the door holder
(See section Door / double-wing door - secure with the door holder).

Access door with flap lock

Functional explanation

- The access door is located at the front end in sales box trailers.
- A step consisting of an aluminium tread plate is fitted on the drawbar for accessing the sales box trailer.
- The access door can be unlatched and locked from the inside and outside.

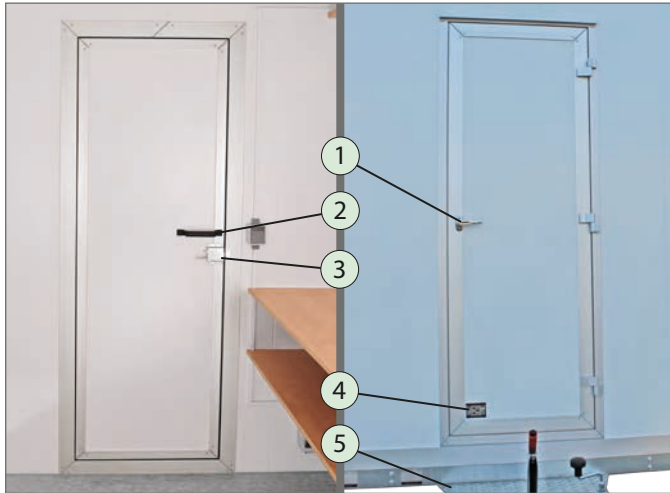

Internal view

External view

1. Door handle
2. Handle
3. Flap lock
4. Door holder
5. Step

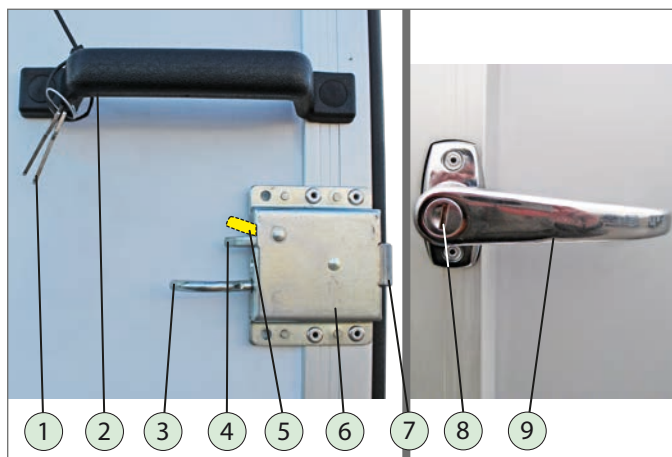

Flap lock inside

Door handle outside

1. Key
2. Handle
3. Hook
4. Locking lever at bottom (open)
5. Locking lever at top (closed)
6. Lock housing
7. Bolt / latch
8. Cylinder lock
9. Door handle

The flap lock can be locked / unlocked from the inside by switching the position of the locking lever.

Opening from the outside



Opening the access door



The sales box trailer must be entered using the step fitted on the drawbar.



CAUTION



Stepping onto the step

You could slip / stumble on the step - falling hazard!

- ▶ Clear any snow / ice before stepping onto the step.
- ▶ Do not place any objects on the step.
- ▶ Step carefully onto the step.
- ▶ Unlock the cylinder lock of the access door if required.
- ▶ Get down from the step and open the access door - turn door handle downwards.
- ▶ Secure the access door with the door holder (See section Access door - Securing with the door holder).

Opening from the inside

- ▶ Opening / closing (See section Sales hatch - Flap lock).
- ▶ Carefully open the access door using the handle.

Closing from the outside

- ▶ Release the access door with the door holder (See section Access door - Releasing with the door holder).
- ▶ Carefully close the access door using the handle until the latch / bolt of the flap lock engages.
- ▶ Lock the cylinder lock of the access door with a key if required.

Closing from the inside

- ▶ Carefully close the access door using the handle until the latch / bolt of the flap lock engages.
- ▶ Lock the access door with the locking lever if required.

Secure with the door holder

NOTICE

Unsecured access door

The access door can be damaged by an impact caused, e.g., by a gust of wind - material damage!

- ▶ After opening the access door, secure it with the door holder.

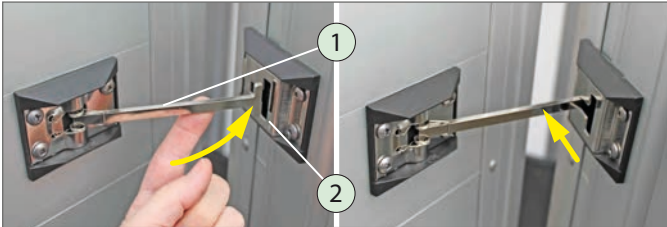

Locking the door holder

1. Locking lever
2. Locking sleeve

- ▶ Open the door until the locking lever can be inserted into the locking sleeve.
- ▶ Guide the locking lever into the locking sleeve.
- ▶ Press the locking lever inwards and up to the limit stop.

The door holder is hooked in.

The access door is now secured.

Releasing with the door holder

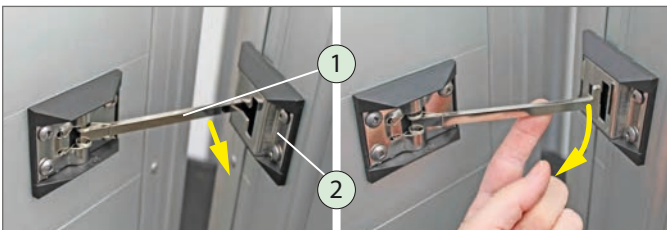

Unlocking the door holder

1. Locking lever
2. Locking sleeve

- ▶ Push the locking lever outwards.
- ▶ Slide the locking lever out of the locking sleeve.
- ▶ Release the locking lever.

The door holder is unlocked.

The access door is unsecured.

6.13 Gas bottle compartment

Functional explanation

- The gas bottle compartment is used to accommodate gas bottles.
- As an option, only an outer door without a closed cabinet can be manufactured.
- The gas bottle compartment is locked from the outside with a square key.



Example: Installed gas system

1. Gas bottle
2. Lashing strap
3. Tie-down points



The operator is responsible for the installation / operation / maintenance of the gas bottles and gas lines!
The gas system must be tested and documented pursuant to trade association regulation BGV D34.

- ▶ Secure the gas bottles to tie-down points with lashing straps.

Opening / closing from the outside

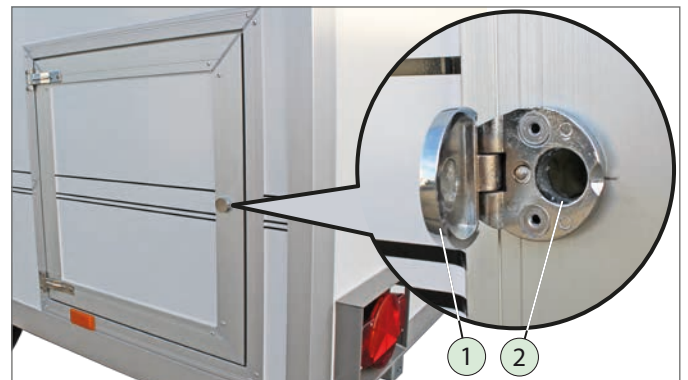

Gas bottle compartment closed

1. Cover
2. Access opening

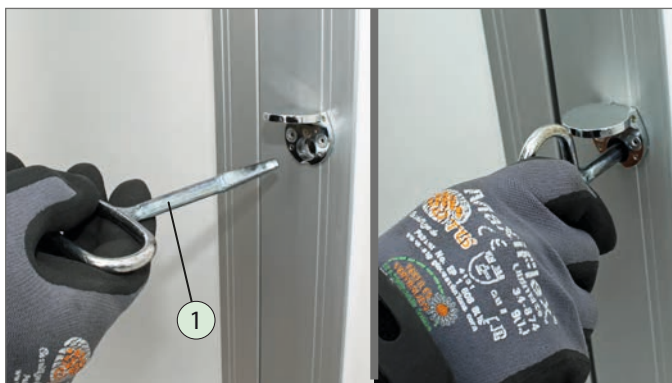

Unlocking the gas bottle compartment

1. Square key

► Unlock / lock the flap with a square key - turn the key.

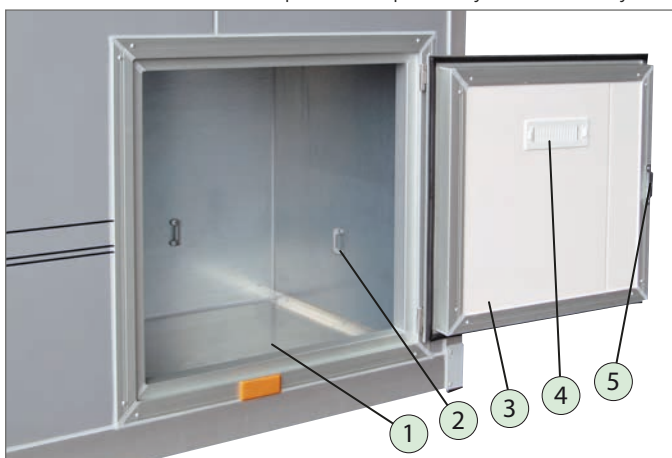

Gas bottle compartment open

1. Gas bottle compartment
2. Tie-down points for gas bottles
3. Flap
4. Side vent
5. Square key lock

Opening / closing from the inside



Gas bottle compartment closed, interior view

1. Fastener
 2. Square key lock
 3. Flap
- Unlock / lock the flap with a square key - turn the key.

6.14 Cable winch + flap

Functional explanation

- The cable winch is located centrally or laterally on the drawbar.
- Defective vehicles can be pulled onto the cargo bed using the cable winch.

6.14.1 Cable winch, manual

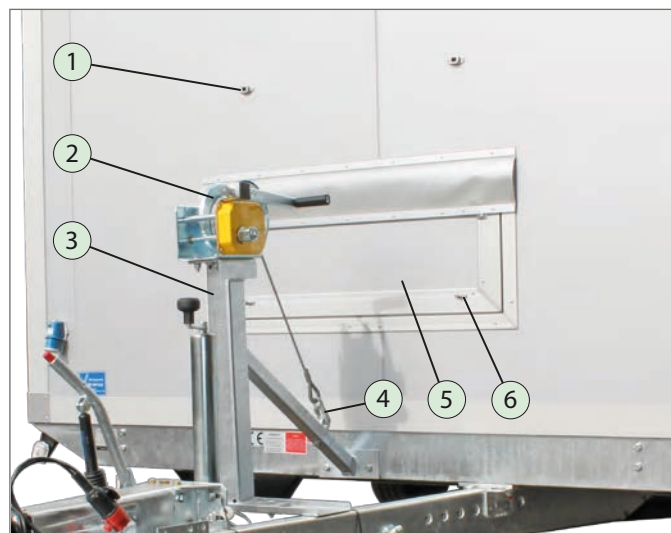

Cable winch frame

1. Retainer (sleeve)
2. Cable winch
3. Frame
4. Snap hook
5. Flap
6. Nipple

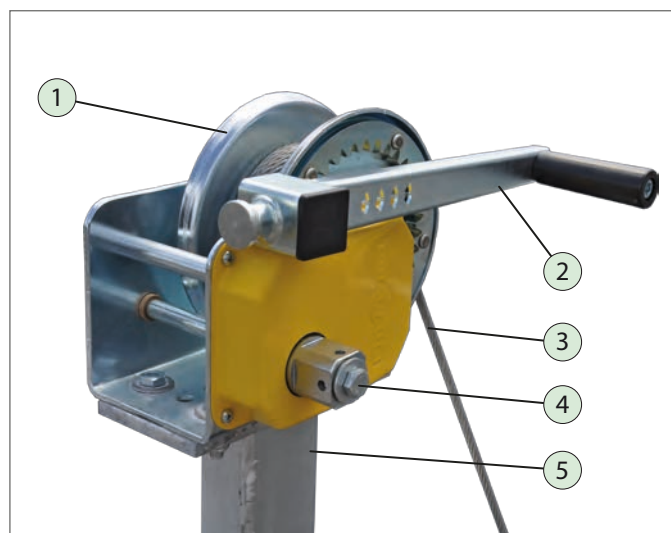

Cable winch frame components

1. Cable winch
2. Crank handle
3. Cable (steel)
4. Crank base
5. Frame, welded

WARNING



Using a damaged cable winch

A damaged cable will be weakened and may tear when placed under load. People could be hit or crushed by the cable and/or the load.

- ▶ Only use the cable winch if it is undamaged and in perfect condition.
- ▶ Have the cable winch regularly serviced and repair it immediately if it is faulty.

CAUTION



Operating the cable winch

You could crush your hands / fingers in the cable winch while rolling or unrolling the cable. You could lacerate your hands on broken individual wires of the cable.

- ▶ Use  .
- ▶ When operating the cable winch, ensure that the cable has no individual broken wires.
- ▶ Ensure that your fingers do not get caught in the cable winch when rolling up the cable.

NOTICE

Overloading the cable winch

Overloading the cable winch may result in it breaking off or the cable tearing.

- ▶ Adhere to the maximum permissible tractive force of the cable winch, i.e., 950 daN or approximately 900 kg.
- ▶ Observe the type label on the cable winch.

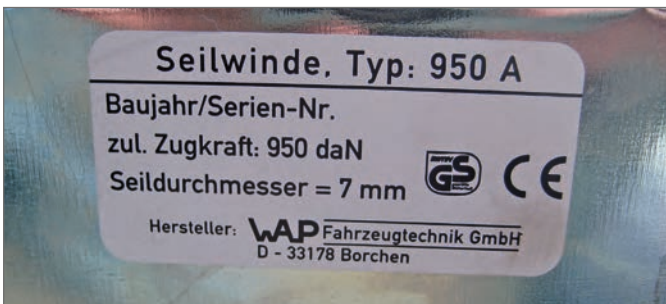

Type label

Preparing the cable winch

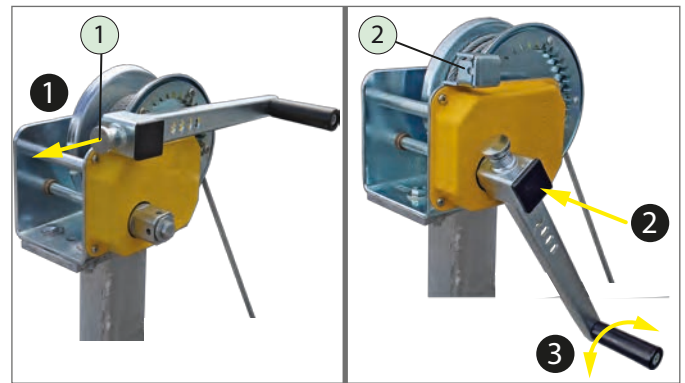

Insert the crank handle

1. Securing pin
2. Parking holder for the crank handle

- ▶ **1** Pull on the securing pin, while at the same time removing the crank handle from its parking position.
- ▶ **2** Insert the crank handle into the crank base. - Simultaneously pull out the securing pin and place it into one of the holes.
- ▶ **3** The crank handle can be turned.



Loosening the snap hooks

- ▶ Relax the cable by turning the crank handle in a counter-clockwise direction.
- ▶ Unhook the snap hook from the eyelet.

Opening the flap



Opening the flap

- ▶ Open the flap
- ▶ Secure it with the retainer.

Extending / unrolling the cable

- ▶ Manually extend the cable.
 - Ensure that the crank handle turns.
 - If necessary, remove the crank handle beforehand.

Securing / winching the load

- ! Amongst others, the loader is responsible for securing the load with tie-down devices!
Winching the load / vehicle is the most dangerous phase during operation of the cable winch!
- ▶ Ensure that nobody is standing in the danger area during loading.

- ! The cable may not be used for load securing.

Rolling up the cable and securing the cable winch

CAUTION

Unsecured cable / crank handle

An unsecured cable / crank handle may rattle around while driving, be torn off and hit a person.

- ▶ Before driving off, ensure that the cable is fastened in the eyelet with the snap hook and pulled tight.
- ▶ Ensure that the crank handle is in the parked position and secured with the securing pin.



Securing the crank handle / snap hook

- ▶ Carefully roll up the cable on the cable winch after use with the aid of the crank handle.
- ▶ Insert the snap hook into the eyelet.
- ▶ Slightly tighten the cable.
- ▶ Remove the crank handle from the crank base.
- ▶ Close / secure the flap.
- ▶ Position the crank handle on the parking bracket.
 - Ensure that the crank handle points in the correct direction (towards the cargo bed).
 - Ensure that the crank handle has been secured.

6.14.2 Cable winch, electric

Functional explanation

- The electric cable winch is available for the vehicle transporter as an option.

- ! Please take note of the safety instructions on the housing of the electric cable winch!
The operator is responsible for the safe operation / maintenance of the cable winch!

- ! Please refer to the enclosed operating manual of the manufacturer for operation of the electric cable winch.

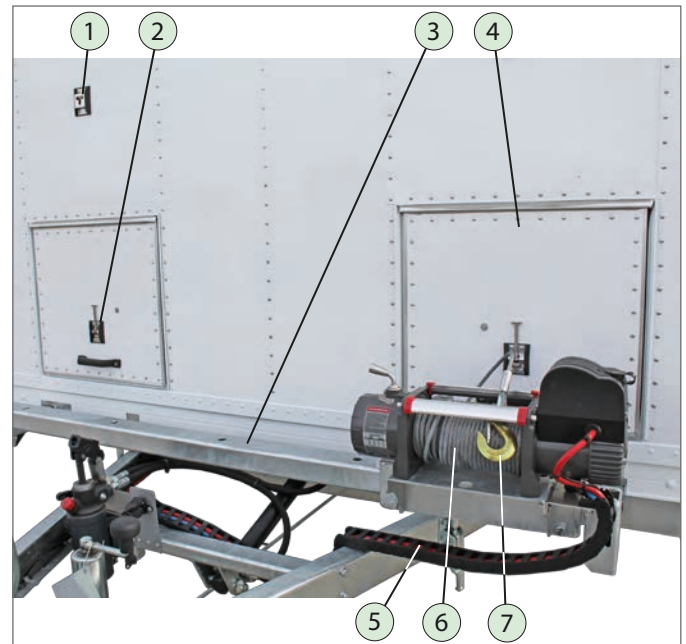

Electric cable winch

1. Locking sleeve
2. Door holder
3. Adjustment rail
4. Flap
5. Supply cable / cable track
6. Cable
7. Hook



View of the interior of the vehicle transporter

6.15 Step

Functional explanation

- An access aid, e.g., a step or tread bar, can be equipped in box trailers with a double-wing door as an option.
- The access aid is extendible and is used for safe access of the cargo bed.



CAUTION



Accessing the cargo bed using the step
You could fall if the step is unsecured / deformed.

- ▶ Only use a secured step.
- ▶ Have a deformed step repaired.
- ▶ Step onto the step with your entire foot.



The step may not be overloaded.
Please take note of the specifications of the manufacturer.



Omnistep

1. Partial step

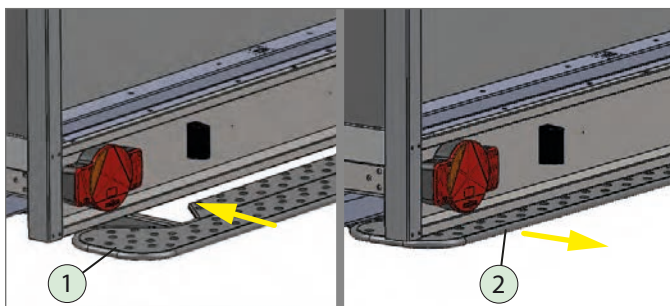

Safety Step

1. Step, extended
2. Step, retracted

- ▶ Pull out the step completely until it locks in position.

Stepping onto the step



Stepping onto the step

- ▶ Step carefully onto the step.



The step must be retracted and secured before driving off.



Safety step

- ▶ Push the step in completely until it engages.

7 Driving

WARNING



Unlocked ramp wall / door / double-wing door / sales hatch

An unlocked ramp wall / door / double-wing door / sales hatch may unintentionally fold down while driving - accident risk!
The goods may then fall out - collision risk!

- ▶ Check that the ramp wall / door / double-wing door / sales hatch are properly closed and locked before driving off.

Unlocked freezer box door

The rotary lever of the freezer box door could open on its own while driving - accident risk!

- ▶ Check that the freezer box door is locked before driving off.



Before setting off, make sure that the maximum permissible loads (load capacity and drawbar load) are not exceeded.



Observe the maximum permissible towing load and drawbar load of your towing vehicle and the trailer coupling.

- ▶ Where required, check the weight information of the goods to be loaded.
- ▶ Carry out a departure check (see operating instruction manual, "Trailers up to 3.5 to" (General Points - Part 1))



Take note of the safety / driving instructions for the towing vehicle and trailer as given in the operating instruction manual "Trailers up to 3.5 to" - General - Part 1.



Your trailer can be licensed for a top speed of max. 100 kph. For this, several conditions must be fulfilled.
- For information, see www.humbaur.com

- ▶ Adapt your driving style to the road and weather conditions!
- Reduce your speed and drive particularly carefully around bends / when turning!
- ▶ Apply the brakes smoothly (not suddenly).



Driving example

7.1 Skylight

Functional explanation

- The skylight is used for fresh air supply.



The skylight must be closed during rain / high winds.

CAUTION



Operating height of the skylight

You could fall, e.g., if you climb on the wheel housing, sales counter, etc. to operate the skylight - stability is not guaranteed.

- ▶ If necessary, use a stable access aid, e.g., a ladder or stool, to operate the skylight.



Skylight closed

1. Rotary handle
2. Anti-insect net
3. Roof vent

Operation



Opening the skylight

- ▶ Turn the rotary handle in a clockwise direction. Skylight is open.
- ▶ Turn the rotary handle in a counter-clockwise direction until the roof vent is completely closed. Skylight is closed.

NOTICE

Overwinding the rotary handle

The mechanical system of the rotary handle could be damaged.

- ▶ Do not turn the rotary handle beyond the end position.

7.2 Sliding window

Functional explanation

- The sliding window is used for fresh air supply.
- The sliding window is equipped with a blackout blind and an anti-insect blind.
- The blackout blind and anti-insect blind can be operated independently of each other.

 The sliding window must be closed during rain / high winds.



Sliding window closed

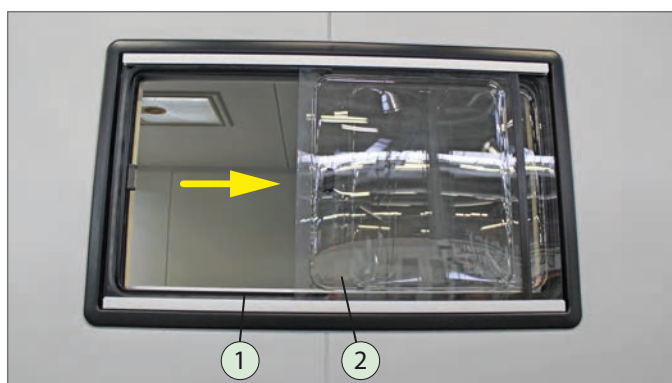

Sliding window open

1. Window frame
2. Sliding window

Unlocking

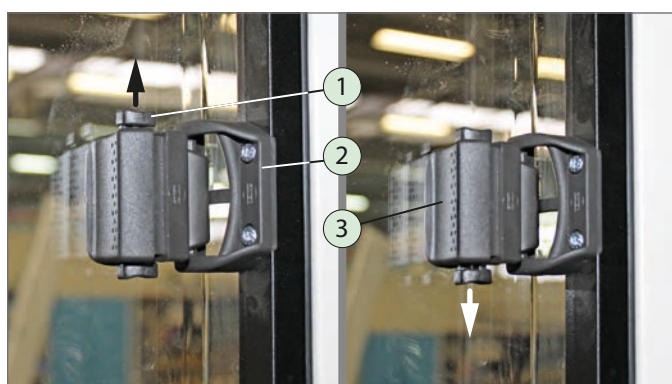

Sliding window lock open

engaged

1. Locking slide
2. Support bracket
3. Locking handle

The sliding window lock is equipped with a locking function. This prevents inadvertent opening of the sliding window.

Operation

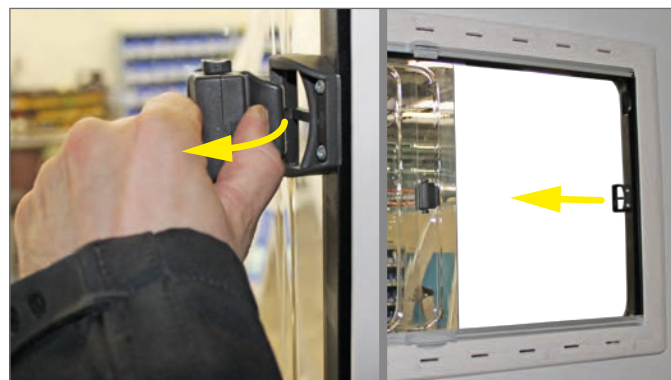

Opening / closing the sliding window

- ▶ Unlocking / locking the sliding window.
- ▶ Slide the window open / closed.

The sliding window is open / closed.

- ▶ When closing the sliding window, ensure that the sliding window lock engages in the support bracket.
- ▶ Lock the sliding window lock with the locking slide.

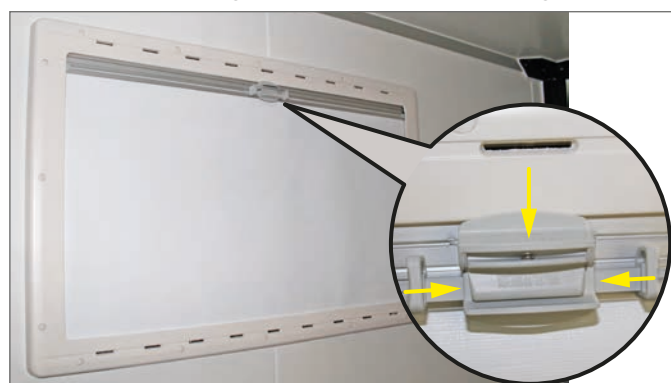

Blackout blind

- ▶ Release the blackout blind lock by compressing the two locking slides.
- ▶ Push the blackout blind up / down.

The blackout blind is closed / open.

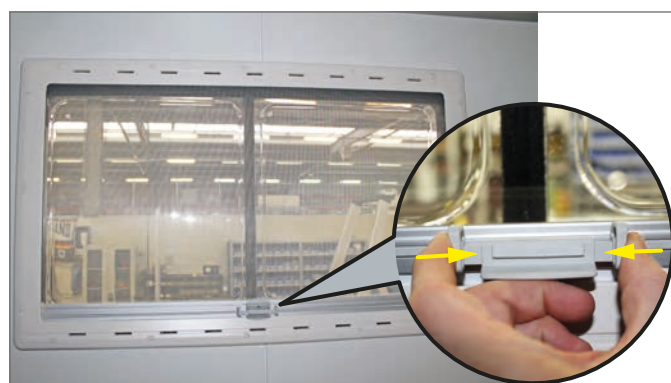

Anti-insect blind

- ▶ Release the anti-insect blind lock by compressing the two locking slides.
- ▶ Push the anti-insect blind up / down.

The anti-insect blind is closed / open.

7.3 Vent window

Functional explanation

- The vent window is used for fresh air supply.
- The vent window is equipped with a blackout blind and an anti-insect blind.

 The vent window must be closed during rain / high winds.



Vent window open, external view

1. Access door
2. Window flap
3. Window frame



Vent window open, view from the inside

1. Blackout blind lock
2. Gas strut
3. Vent window lock
4. Anti-insect blind lock

Opening

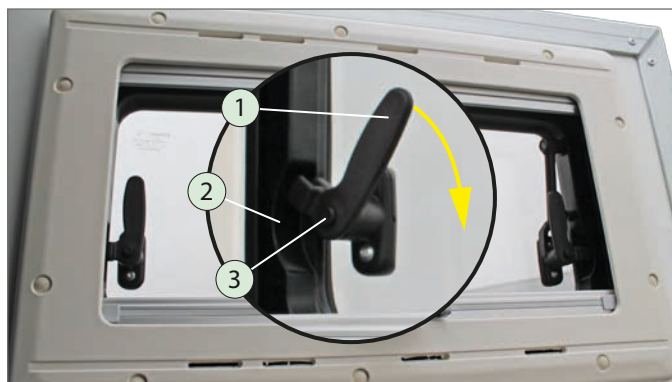

Unlocking the vent window

1. Lever
2. Recess
3. Button

▶ Press the button and turn the levers towards the centre by 90°.

▶ Use the levers to press the window flap outwards.

The window flap is open.

Closing

▶ Use the levers to pull the window flap inwards.

▶ Turn the levers by 90° so that the levers lock the window flap in the recesses.

The window flap is closed.

Blackout blind

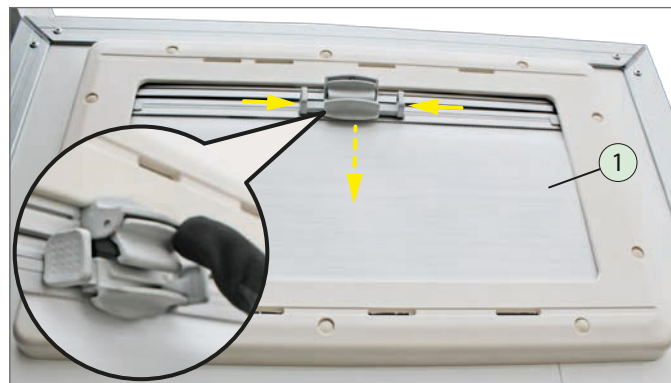

Blackout blind closed

1. Blackout blind

▶ Release the blackout blind lock by compressing the two locking slides.

▶ Push the blackout blind up / down.

The blackout blind is closed / open.

Anti-insect blind



Anti-insect blind closed

1. Anti-insect blind

▶ Release the anti-insect blind lock by compressing the two locking slides.

▶ Push the anti-insect blind up / down.

The anti-insect blind is closed / open.

7.4 Lights

7.4.1 Interior light (optional)

Functional explanation

- The interior light can be switched on using the toggle switch on the light when it is dark, e.g., for loading/unloading, if at least the parking light is switched on in the towing vehicle.



Interior light (12 V)

1. Toggle switch
2. Light

Replacing the lamp



Opening the interior lighting

- ▶ Push the plastic cover downwards.
- ▶ Remove the plastic cover.

Lamp can be replaced.



Interior lighting open

- ▶ Insert a lamp of the same type / output.
- ▶ Place the plastic cover on the lighting housing.
- ▶ Push the plastic cover upwards.

Interior lighting is fixed and closed.

7.4.2 Linear luminaire (optional)

Functional explanation

- The linear luminaire is used when it is dark, e.g., for loading/unloading.
- The linear luminaire requires an external power source of 230 V.
- The main use is in sales and freezer box trailers as well as Cool Trailers.

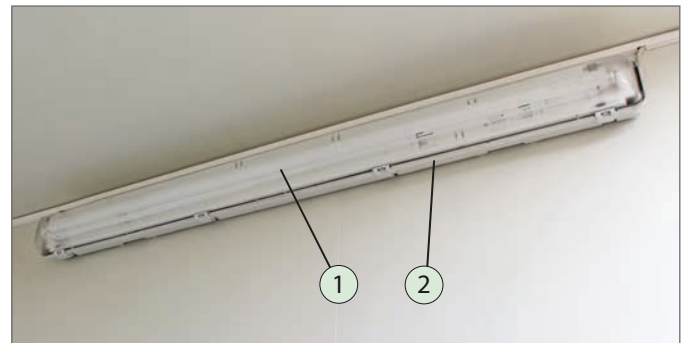

Interior light (230 V)

1. Fluorescent tube
2. Housing (damp-proof)

7.4.3 Light switch (optional)

Functional explanation

- The interior lighting can be switched on using a separate light switch.
- The light switch is used for the interior light (12 V) or linear luminaire (230 V).



Light switch

1. Light switch (damp-proof)

- ▶ Use the light switch to switch on the interior lighting for loading / unloading.

8 Parking

 Observe the general safety and warning instructions on safely parking your trailer in the operating instruction manual "Trailers up to 3.5 to" (General Points - Part 1).

- ▶ Furthermore, ensure that
 - the ramp wall / door / double-wing door / sales hatch and access door are closed and secured and
 - the skylight / side window is closed, if necessary.
- ▶ Park the trailer where possible on level ground / an even surface - not on a slope or on an uphill / downhill incline.
- ▶ Secure an unbraked trailer with wheel chocks / wooden elements as far as possible.

 Both wheels of an axle must be supported in only one direction in single-axle box trailers, in order to prevent the trailer from rolling away on one side.

In order to prevent the brake linings from sticking and freezing:

- ▶ Release the hand brake if parking for longer periods
 - especially in wet and cold weather conditions and frost.
 - Secure the trailer only with wheel chocks before releasing the brake.

Parking a trailer includes the following:

- Parking for loading/unloading
- Parking for longer periods, unloaded, uncoupled
- Parking for longer periods, loaded, uncoupled

 The operator is responsible for safety and theft protection when parking sales / refrigerated box trailers.

Parking a sales box trailer

- for mobile sales activities
- Parking without interior equipment
- Parking with fitted appliances, e.g., stove, sink unit, refrigerator

Parking a refrigerated box trailer

- Parking with chilled goods
 - with connection of an external power supply to prevent the goods from spoiling.
- Parking without chilled goods
 - regular opening and ventilating is required to prevent the growth of mould.

8.1 Parking an uncoupled trailer

Using wheel chocks



Position: on the side of the chassis under the body



Position: on the front end of the body

1. Lever
2. Holder
3. Wheel chock

- ▶ Press the lever of the holder.
- ▶ At the same time, remove the wheel chock.



Placing the wheel chocks, tandem

- ▶ Place the wheel chocks under the wheels - watch out for the inclination of the road while doing so.

8.1.1 Unloaded parking



Example: parked unbraked trailer

- ▶ When parking for longer periods, park the trailer tilted forwards as far as possible.
- ▶ Use wheel chocks / wooden elements if possible.

NOTICE

Snow / ice on the roof

The roof surface can be damaged if the snow / ice load is too high.

- ▶ Park the trailer tilted forwards, so that standing water and possible ice formation on the roof can be prevented.

Clearing the roof

The roof can be damaged / scratched if a snow shovel or scraper is used.

- ▶ Clear the roof, e.g., with a broom with soft bristles.



Snow / ice load



Keep off the roof of the box trailer.

- ▶ Regularly remove foreign objects, snow / ice loads from the roof.
- ▶ Use a stable access aid, e.g., a step ladder, when clearing the roof.

8.1.2 Loaded parking

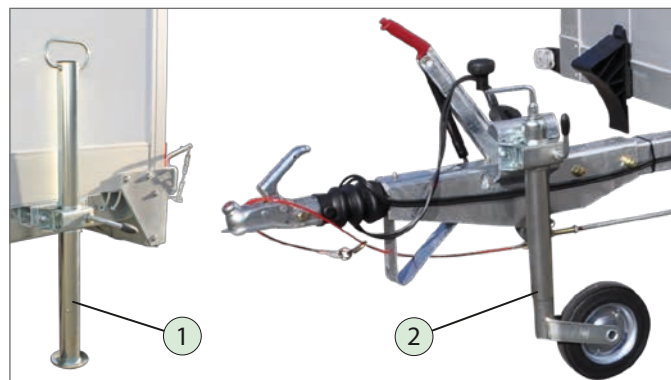

Support lowered

1. Prop stand
2. Jockey wheel

- ▶ Secure the trailer with supports.
- ▶ Lower the jockey wheel.
- ▶ Position the trailer horizontally as far as possible.

8.2 Manoeuvring



Manoeuvring is only permitted when the trailer is not loaded.

- ▶ Lower the jockey wheel.
- ▶ If necessary close the ramp wall / access door / sales hatch.



Manual manoeuvring of the trailer

1. Handle (on the front)
 - ▶ Use the handle at the front of the trailer for manual manoeuvring.
 - ▶ Pull / push the trailer in the desired direction.
 - ▶ Ensure that your feet are never under the jockey wheel.
 - ▶ Use  .
 - ▶ Apply the handbrake.

8.3 Ventilating / drying the inside

- ▶ Allow the inside of the trailer to dry out to prevent growth of mould and damage due to humidity.
- ▶ Regularly ventilate the closed body.

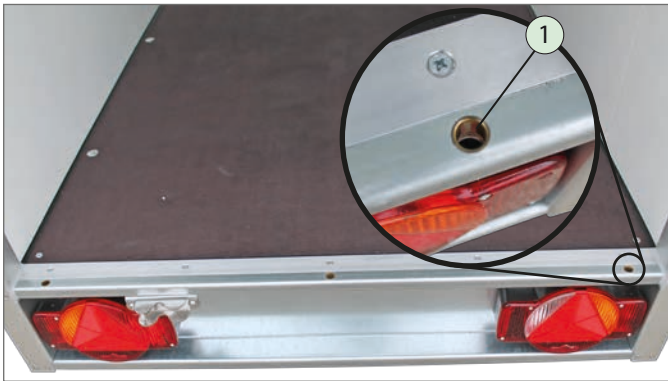

Water drainage

1. Water drainage hole

Water / condensate accumulating in the interior can be conducted away using the water drainage holes.



Doors open

- ▶ Open all doors / flaps where possible and ventilate the inside.



Skylight open



Side window open



Side vent as forced ventilation

- ▶ If required, leave the optional vents open permanently, in order to prevent possible moisture build-up.

8.4 Sales box trailers



Corner legs lowered

- ▶ In addition to the brake / wheel chocks, secure the sales trailer with corner legs when using it for sales activities.
- ▶ If required, use the corner legs to compensate for uneven ground.

8.5 Refrigerated box trailers



Telescopic prop stands lowered

- ▶ In addition to the brake / wheel chocks, secure the refrigerated box trailer with telescopic prop stands when loading / unloading and parking for longer periods.
- ▶ If required, use the telescopic prop stands to compensate for uneven ground.

8.6 Refrigerating unit (optional)

Functional explanation

- The refrigerating units are only suitable for stationary operation - do not operate while driving.
- The refrigerated box trailer should only be loaded with pre-cooled goods. The cooling system maintains the pre-cooled temperature of the goods.
- The refrigerating system should be started approx. 24 hours before loading the chilled goods, so that the desired cooling temperature is reached.
- If possible, the refrigerating unit should be parked in the shade / not exposed to direct sunlight.
- The refrigerating unit must be left to stand for approx. 1 hour after driving, so that the coolant settles.
- The refrigerating unit is operated with a stationary external power source (230 V AC).



Adequate air circulation must be provided in the cooled interior:

- Distance between chilled goods and inside wall: 70 mm
- Distance between chilled goods and ceiling: 1/3 of the interior height
- distance between chilled goods and front wall: 1000 mm



CAUTION



Operating height of the refrigerating unit

You could fall if you stand on the drawbar to operate the refrigerating unit.

- ▶ If required, use a stable access aid, e.g., a ladder or stool, to operate the refrigerating unit.
- ▶ If necessary, use the access aids, e.g., steps or folding step, fitted to the trailer.



8.6.1 Mains supply

Functional explanation

- The refrigerating units are supplied from a mains supply via a power plug (230 V AC).
- An adapter cable with a pre-assembled power plug is available as an option.



The current source must be fuse-protected in accordance with the refrigerating unit. The performance data can be found on the type label and in the operating instructions of the refrigerating unit.



Mains connection of refrigerating unit

1. Connection diagram
2. Mains supply
3. Cover



Opening the mains connection

- ▶ Open the cover.
- ▶ Remove the cover.
- ▶ Connect the power plug.

Adapter cable (optional)



Adapter cable 2.5 m long with power plug

Providing the supply voltage



The cable may only be connected to the power plug by a qualified electrician.



WARNING



Shock hazard / short-circuit hazard!

You could be exposed to dangerous voltage or cause a fire through a short circuit in the electric system if you carry out work on the electric system.

- ▶ Do not carry out any work on the electric system.
- ▶ Ensure that nobody else switches on the power supply.
- ▶ Have maintenance and repair work carried out by a qualified electrician.

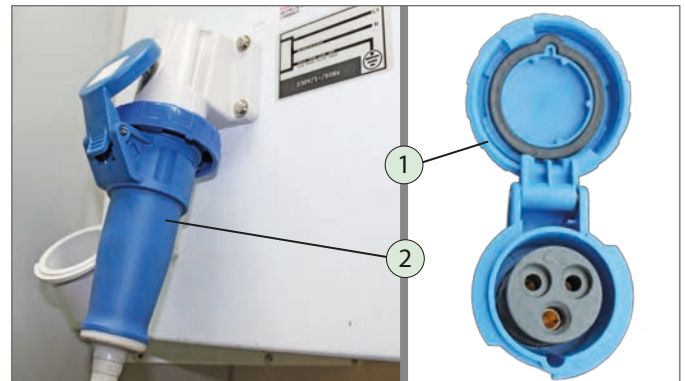

Supply voltage connected

1. Power plug cover
2. Power plug

- ▶ Open the cover.
- ▶ Connect the power plug to the mains connection of the refrigerating unit.
- ▶ Switch on the power supply.

8.6.2 Documentation and conformity



The refrigerating units comply with the respective European Directives and have a CE mark of conformity. The technical data and the manufacturer are stated on the type label on the unit.



Please refer to the provided supplier's documentation. Compliance with commissioning / operation / maintenance / service and cleaning is mandatory.



The operator is responsible for complying with the prescribed maintenance intervals of the refrigerating units. The warranty becomes null and void in the event of unauthorised changes / modifications to the refrigerating unit. Conformity with European Directives and standards is no longer provided.

8.6.3 Units for Cool Trailers

8.6.3.1 AS Rotary refrigerating unit (Zanotti) - HCU 1

Functional explanation

- **Area of application:**
Unit for Cool Trailer
- **Cooling temperature adjustment range:**
+ 5° C to + 15° C
- **Permissible environmental temperature:**
+ 12° C to + 43° C
- **Cold room size**
Model MAS121T943S/HMB: 5 - 12 m³
- **Voltage supply:**
230 V 1 Ph + N + Pe 50 Hz
- **Cooling power at a cooling temperature of + 5° C, outside temperature Ta) + 32° C:**
Model MAS121T943S/HMB: 1460 Watt
- **Power consumption when cooling at Ta + 32° C:**
Model MAS121T943S/HMB: 828 Watt
- **Air volume stream of vaporiser:**
Model MAS121T943S/HMB: 700 m³ / h
- **Weight:**
57 kg



Internal view

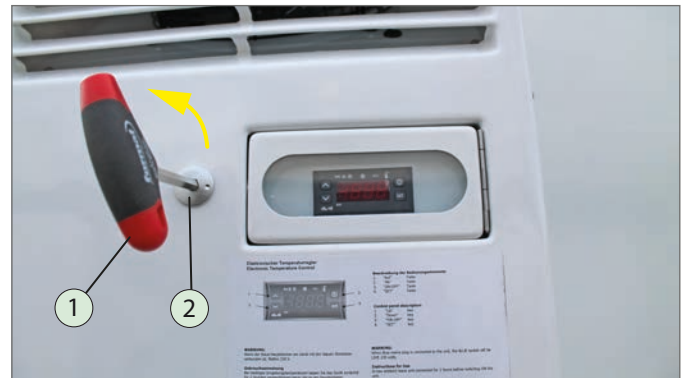

Opening the flap

1. Security key
2. Locking bolt

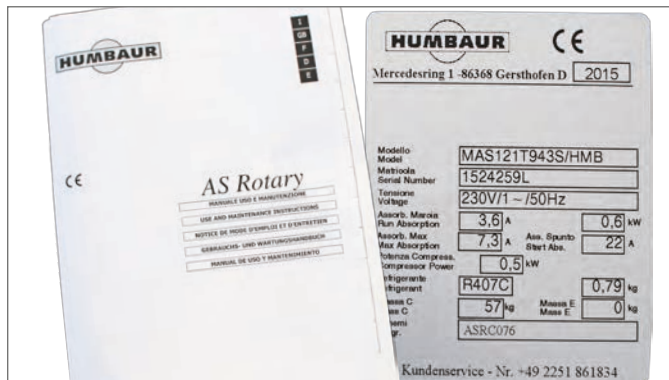

Operating instructions

Type label

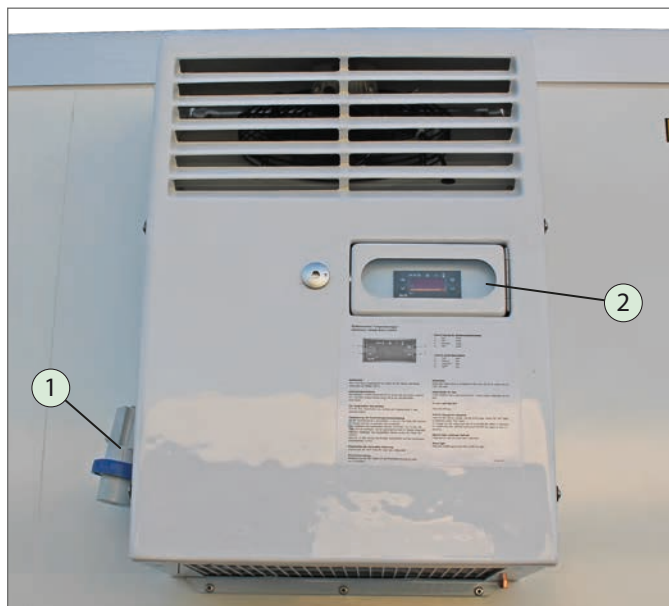

External view

1. Mains supply
2. Operating element

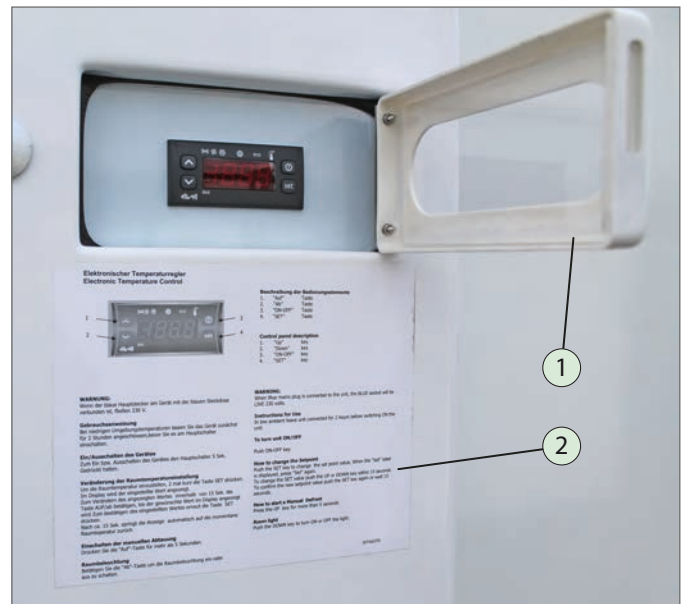

Control panel open

1. Flap
2. Instructions

- ▶ Unlock the flap with the security key.
- ▶ Set the unit as described in the instructions.
- ▶ After setting, close the flap and lock it.

8.6.3.3 HCU 2, 3 refrigerating units (CIBIN)

Functional explanation

- **Area of application:**
Unit for Cool Trailer
- **Cooling temperature adjustment range:**
+ 5° C to + 15° C
- **Permissible environmental temperature:**
+ 12° C to + 43° C
- **Cold room size**
Model HCU 2: 7 - 14 m³
Model HCU 3: 10 - 18 m³
- **Voltage supply:**
230 V 1 Ph + N + Pe 50 Hz
- **Cooling power at a cooling temperature of + 5 °C, environmental temperature + 32 °C:**
Model HCU 2: 1850 Watt
Model HCU 3: 2450 Watt
- **Power consumption when cooling at Ta + 32 °C:**
Model HCU 2: 884 Watt
Model HCU 3: 1528 Watt
- **Air volume stream of vaporiser:**
Model HCU 2: 700 m³ / h
Model HCU 3: 1400 m³ / h
- **Weight:**
xx kg



Internal view of HCU

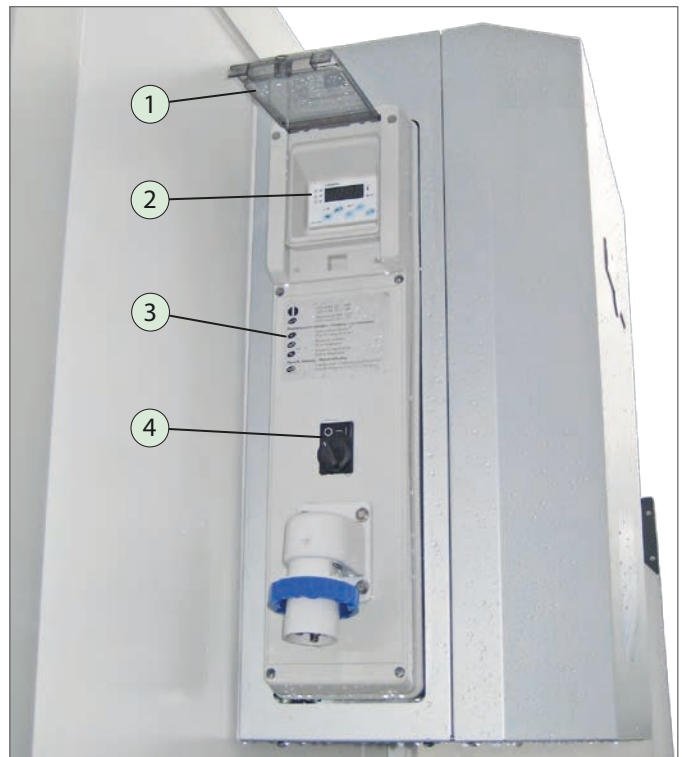

Control panel open

1. Flap
2. Control panel
3. Instructions
4. On / off switch

- ▶ Unlock the flap.
- ▶ Set the unit as described in the instructions.
- ▶ After setting, close the flap and lock it.



Operating instructions

Type label

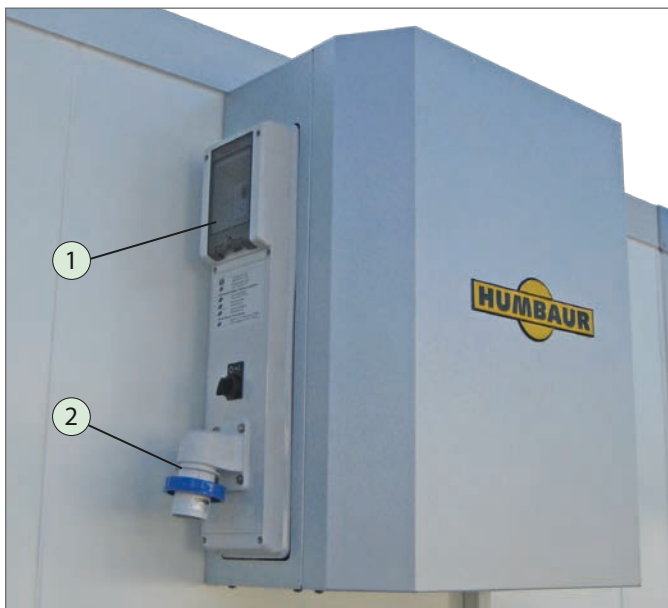

External view of HCU

1. Operating element
2. Mains supply

8.6.4 Freezer box trailer unit

8.6.4.1 Alaska refrigerating unit (CIBIN)

Functional explanation

- **Area of application:**
Unit for freezer box trailer
- **Cooling temperature adjustment range:**
+ 10 °C to + 18 °C
- **Permissible environmental temperature:**
Model 240 OBN: + 10 °C to + 38 °C
Model 330 VBN: 0 °C to + 38 °C
- **Cold room size**
Model 240 OBN: m³
Model 330 VBN: m³
- **Voltage supply:**
230 V 1 Ph + N + Pe 50 Hz
- **Cooling power at a cooling temperature of - 18 °C, environmental temperature + 32 °C:**
- Model 240 OBN: 1300 Watt
Model 330 VBN: 2010 Watt
- **Power consumption when cooling at Ta + 32 °C:**
Model 240 OBN: 1740 Watt
Model 330 VBN: 2630 Watt
- **Air volume stream of vaporiser:**
Model 240 OBN: 1400 m³ / h
Model 330 VBN: 2000 m³ / h
- **Weight:**
75 kg



External view

1. Operating element
2. Mains supply



Internal view



Detail of operating element / mains connection

1. Flap



Control panel

- ▶ Unlock the flap.
- ▶ Set the unit as described in the instructions.
- ▶ After setting, close the flap and lock it.



Operating manuals



Type label 240 OBN

Type label 330 VBN

8.7 Power generator (optional)

Functional explanation

- The power generator is mounted on the drawbar.
- It is driven by diesel / petrol.
- It produces a maximum current of 230 V AC and is specified for the operation of a refrigerating unit.
- The power generator is provided with a cover to protect it from the effects of weather and dirt accumulation.
- The power generator is mainly used in freezer box trailers.



The power generator should only be operated when the trailer is at standstill.

Oil starvation could occur while the vehicle is moving, especially in bends, which could cause damage to the motor. The operator is liable for any damage if the power generator is operated while the vehicle is moving.

NOTICE

Operation of the power generator while the vehicle is moving

The power generator could suffer a defect during extreme cornering.

- ▶ Drive extremely slowly and carefully in bends / gradients / extreme road conditions.
- ▶ Check the oil level in the unit before setting off.
 - Top up oil if required.



Read the operating instructions of the manufacturer to find out more about the safety information of the power generator.

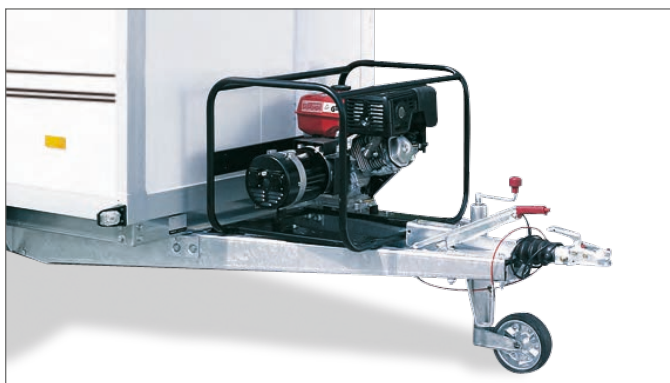

Example: Power generator manufactured by HONDA (shown without cover)

8.8 Distributor box (optional)

Functional explanation

- The safety and function of the power supply are tested in the factory and documented. The test record is enclosed with the distributor box.
- The power is supplied via a commercially available mains connection (plug coupling) on the outer wall.
- The mains voltage is 230 V / 50 Hz.
- The distributor box contains a residual-current circuit breaker (30 mA) and an overcurrent protection device with 10 A or 16 A.
- The trailer can be equipped with country-specific socket outlet with earthing contact as an option.



WARNING



Shock hazard / short-circuit hazard!

You could be exposed to dangerous voltage or cause a fire through a short circuit in the electric system if you carry out work on the electric system.

- ▶  Switch the power supply off without fail prior to carrying out work on electric systems.
- ▶ Ensure that nobody else switches on the power supply.
- ▶ Have maintenance and repair work carried out by a qualified electrician.

As an option, sales box trailers and refrigerated box trailers can be equipped with a mains connection with a distributor box and sockets.

The power supply can be provided by means of an adapter cable (optional) with a power plug.

Power is required for appliances installed in the sales box trailer, e.g., refrigerator, stove, dish washer, etc., or for the lighting system, e.g., a linear luminaire.

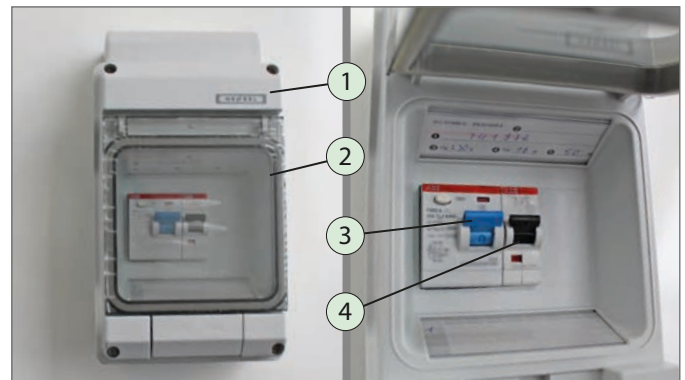

Distributor box

1. Distributor box
 2. Flap
 3. Residual-current circuit breaker
 4. Overcurrent protection device
- Standard: 16 A
Switzerland: 10 A

The distributor box is located on the inner wall of the box trailer, usually on the front wall.

8.9 Platform

Functional explanation

- As an option, a box trailer can be equipped with a platform which can be folded out.
- A platform can be executed as a stair platform or a stage platform.



The operator must contact the manufacturer with regard to the maximum load capacity before bringing the platform into service.

The operator is responsible for the structural stability and compliance with the accident prevention regulations during use of the platform.



It takes two people to handle large platforms / advertising panels.

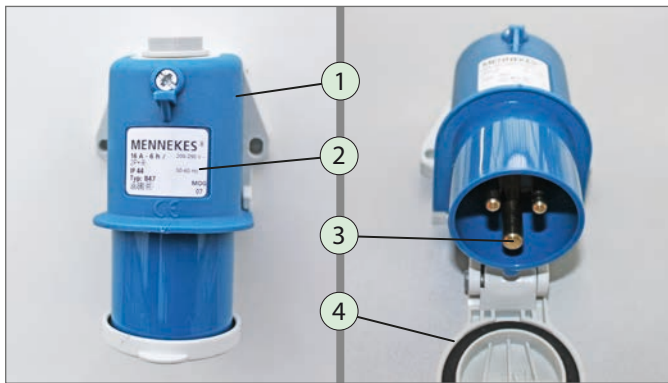

Mains supply (230 V AC)

1. Mains supply
2. Technical Data
3. Plug contact
4. Cover

The mains connection is usually located on the outer front wall.



Adapter cable 2.5 m long with power plug (optional)

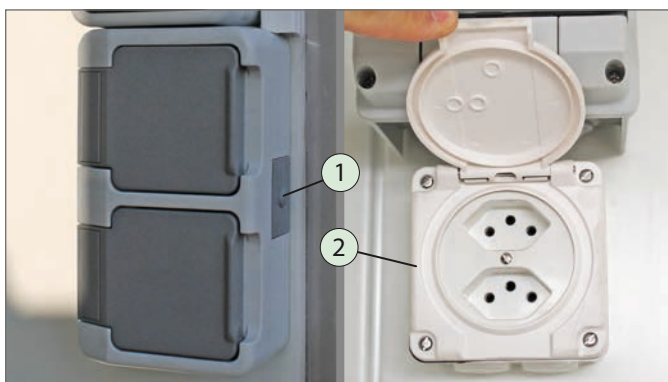

Socket outlet with earthing contact, Swiss version

1. Twin socket with earthing contact
2. Twin socket, Swiss version

The sockets can be positioned anywhere in the trailer.

CAUTION



Accessing the platform

You could slip off the platform and fall. There is an increased risk of slipping in wet conditions / snow / dirt!

- ▶ Remove dirt / snow / moisture from the platform as required.
- ▶ Use .
- ▶ Do not jump off the platform.
- ▶ Move carefully and step onto the steps with your entire foot.



Folding out the platform

You can hit your head! A platform is large and heavy. It can fold down unexpectedly - risk of impact!

- ▶ Carefully fold out small platforms with both hands.
- ▶ Handle large platforms with two people.
- ▶ Keep people away from the area around the platform when folding it down.

8.9.1 Stair platform



Closed box trailer (driving position)

1. Sales hatch
2. Advertising panel
3. Retainer for advertising panel
4. Espagnolette lock



Stair platform folded down

1. Advertising panel
2. Gas strut
3. Stair platform

Opening the advertising panel

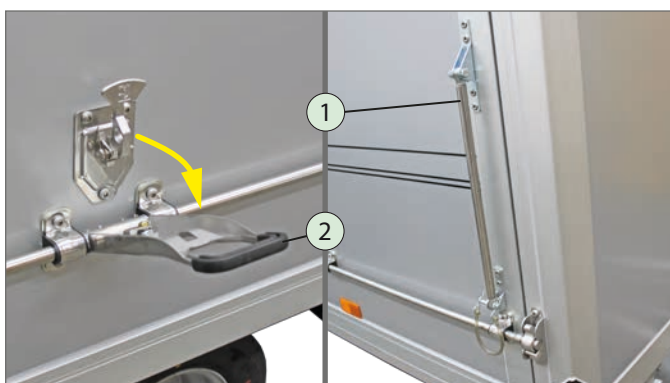

Unlocking the advertising panel

1. Retainer
2. Espagnolette lock

- ▶ Unlock the espagnolette lock.

Retainer secured

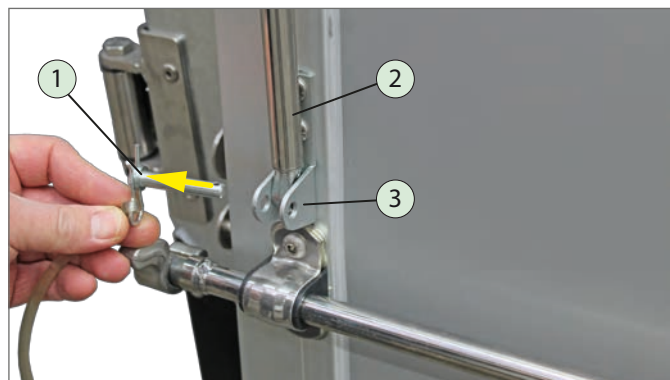

Reposition the retainer

1. Plug pins
2. Retainer
3. Bottom hinge bracket

- ▶ Release the plug pins - pull out the cotter pins.
- ▶ Lift the advertising panel into the horizontal position and hold it firmly.
- ▶ Switch the position of the retainers, so that the end is located in the top hinge bracket.



Securing the retainer

1. Top hinge bracket
2. Cotter pin

- ▶ Secure the retainers with the plug pins and the cotter pins.



Advertising panel open / secured

Opening the sales hatch

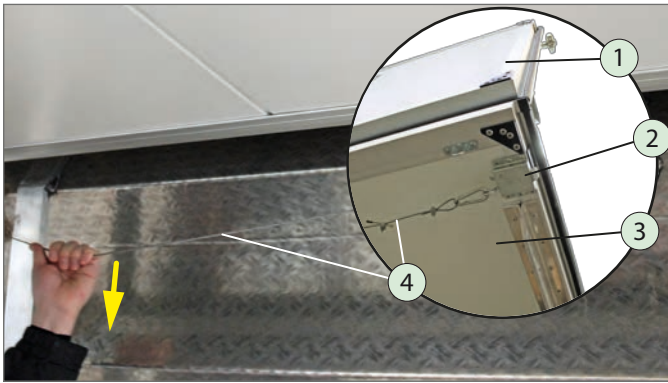

Releasing the sales hatch

1. Advertising panel
2. Flap lock
3. Sales hatch
4. Cable

- ▶ Pull on the middle of the cable.

The flap locks are released.

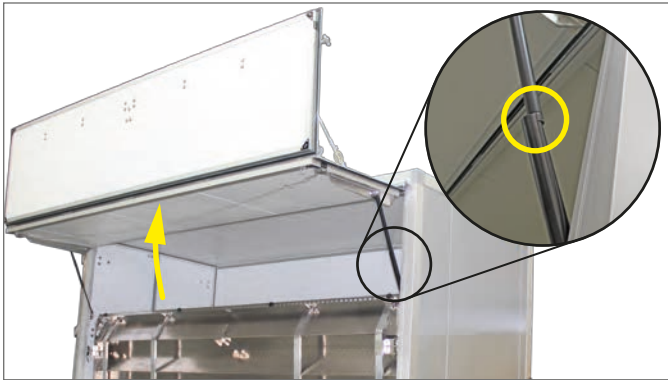

Sales hatch open and secured

- ▶ Fold the sales hatch upwards.
 - The gas struts will support you in the process.
- ▶ - Secure the gas strut.
 - Turn the piston retainer by 180°.

Folding down the stair platform

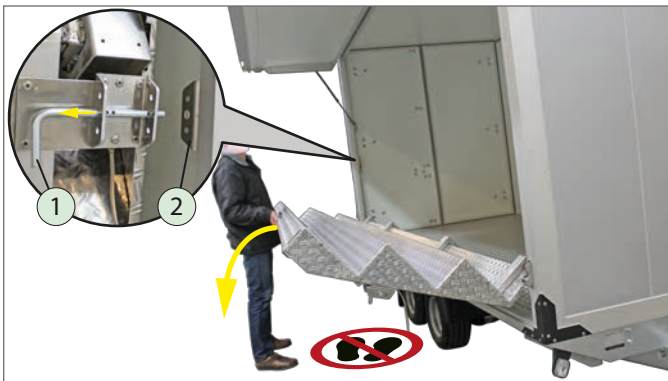

Releasing / unfolding the stair platform

1. Bolt
2. Striking plate

- ▶ Release the bolts - pull out the cotter pins.

- ▶ Pull the bolts out of the striking plates.
- ▶ Carefully fold down the stair platform.



Stair platform unfolded

Stair platform is ready for use

Sales hatch with advertising panel is secured.

Closing



Folding up / securing the stair platform

1. Cotter pin

- ▶ Fold up the stair platform
- ▶ Secure the stair platform on each side with the bolts and cotter pins.

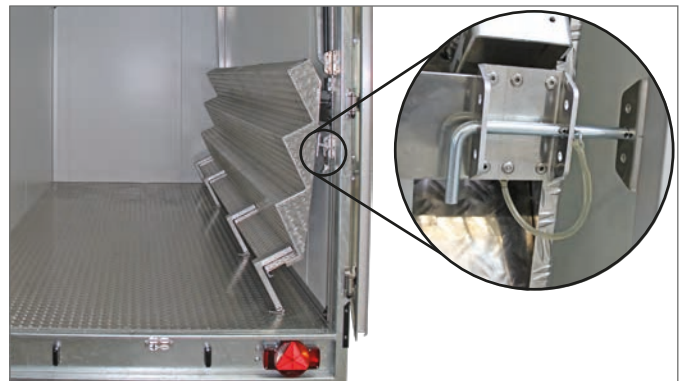

Stair platform secured

Stair platform is secured

8.9.2 Stage platform

Functional explanation

- The stage platform is suitable for advertising and sales purposes.
- The stage platform is accessed using the steps.
- The stage platform is raised and lowered by means of a cable winch.

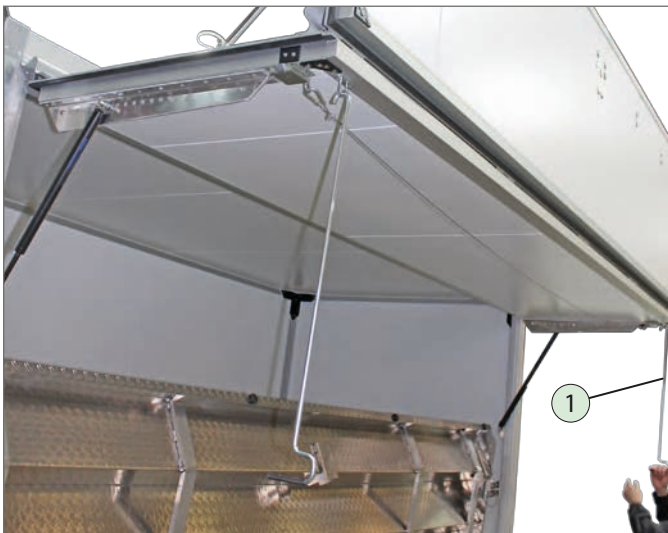

Closing the sales hatch

1. Operating rod

- ▶ Release the gas strut.
- ▶ Pull the sales hatch downwards using the operating rods with hooks on each side and hold it firmly.
- ▶ Remove the operating rods.
- ▶ Press the sales hatch inwards until the flap locks engage.
- ▶ Release the retainers of the advertising panel.
- ▶ Close the advertising panel.
- ▶ Insert the retainers into the bottom hinge bracket and secure them in the folded position.
- ▶ Secure the advertising panel with the espagnolette lock.



Box trailer in the driving position

Sales hatch with advertising panel is closed and secured.



Stage platform closed (driving position)

1. Lock
2. Cable
3. Cable winch
4. Trailer supports



Stage platform open

1. Steps
2. Sales hatch
3. Guard rails
4. Stage platform
5. Support leg



The stage platform may only be extended on a sufficiently large and level standing surface.

- ▶ Lower the trailer supports.
- ▶ Release the stage platform and the support legs.
- ▶ Lower the stage platform by means of the cable winch and extend the support legs.
- ▶ Attach the guard rails and lock them.
- ▶ Attach the steps to the stage platform.
- ▶ Check the stability of the stage platform.

8.10 Ladder

Functional explanation

- The ladder is provided for accessing the structures on the roof, e.g., the advertising panel.
- The ladder consists of a fixed section and an extendible section.

CAUTION



Climbing onto the roof using the ladder!

You could slip off the ladder and fall.
There is an increased risk of slipping in wet conditions / snow / dirt!

- ▶ Remove dirt / snow / moisture from the ladder as required.
- ▶ Use  .
- ▶ Keep a firm grip on the ladder when climbing up / down.
- ▶ Move carefully and step onto the steps with your entire foot.



Folding down the ladder

You can hit your head!

- ▶ Carefully fold down the extendible ladder section with both hands.

Fold down



Ladder unfolded

1. Fixed ladder section
2. Extendible ladder section

- ▶ Release the extendible ladder section - open the lock.

- ▶ Fold down the extendible ladder section.

The ladder is resting on the front wall and can be used.

Folding up



Ladder folded up / secured

- ▶ Fold up the extendible ladder section and secure it with the lock.



Ladder secured (driving position)

1. Mounting bracket
2. Locking

8.11 Advertising panel frame

Functional explanation

- The frame is provided for mounting advertising panels.
- The frame can be raised / lowered.
- Operators can mount their own advertising panels.



The mounting and safety of the advertising panel is the responsibility of the operator.
The advertising panel may not exceed the overall dimensions of the trailer roof.

CAUTION



Operating the advertising panel frame

You can crush your hands!
You can fall from the roof!

- ▶ Remove dirt / snow / moisture from the roof as required.
- ▶ Use .
- ▶ Move extremely carefully on the roof.

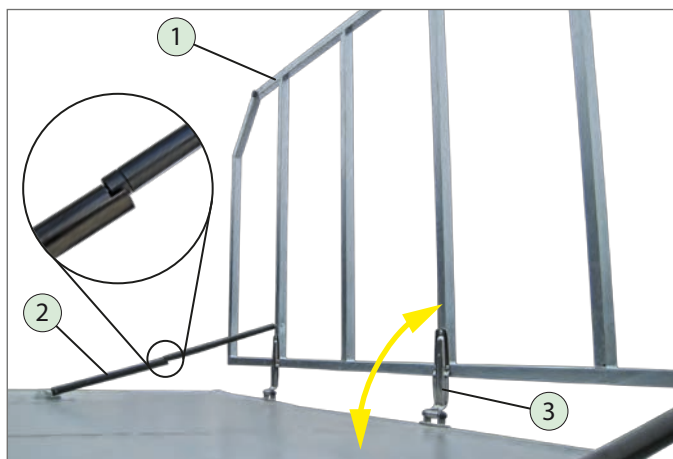

Advertising panel frame raised

1. Advertising panel frame
2. Gas strut secured
3. Hinge
 - ▶ Release the locking bolts.
 - ▶ Raise the advertising panel frame.
 - ▶ Secure one of the gas struts.

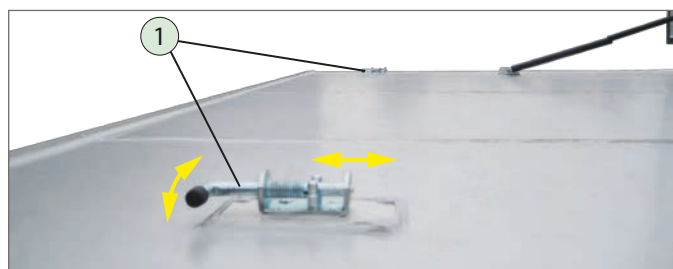

Securing for driving position

1. Locking bolt
 - ▶ Release the frame and lower it.
 - ▶ Secure the frame with the locking bolt.

9 Cleaning / maintenance / servicing

9.1 Care / cleaning



Observe the safety instructions and instructions for general cleaning / care of trailers in the operating instruction manual "Trailers up to 3.5 to" General Points - Part 1.

NOTICE

Cleaning the inside

The side walls / floor are glued and sealed - a high-pressure jet can dissolve the glue / sealing and lead to water / humidity damage.

- ▶ Do not clean the inside of the trailer with a high-pressure cleaner / steam cleaner.
- ▶ Use only water at normal pressure, e.g., from a hose pipe, to clean the inside area.
- ▶ Wash the inside walls with lukewarm water and neutral detergent by hand, e.g., with neutral soap.

Cleaning the outside of the box

The sealing (silicone joints) could be damaged by a direct water jet from a high-pressure cleaner.
The box body may not be watertight.

- ▶ Do not aim the water jet directly at the sealing (silicone joints).
- ▶ Keep a minimum distance of approx. 80 cm from the sealing (silicone joints).

Water drainage

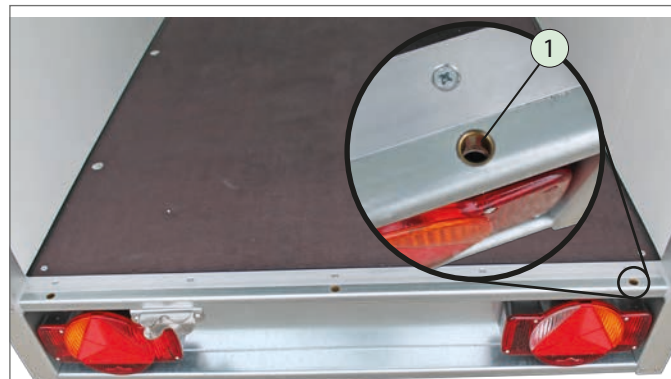

Water drainage

1. Water drainage hole
 - ▶ Remove dirt / blockages from the water drainage holes.

Cleaning the roof / surface

- ▶ Regularly remove debris such as bird droppings, branches, leaves and snow from the roof of the box trailer.
- These could attack the surface and damage it in the long term.
- ▶ Pre-treat heavily soiled areas with pH-neutral cleaning agents.

9.2 Maintenance / servicing

9.2.1 Tyres / wheels

- ▶ Check the tyre pressure on all wheels on a regular basis and before long journeys.
(See the table: Maintenance instructions in the operating instruction manual "Trailers up to 3.5 to General Points - Part 1")

The following tyre sizes can be used:

Tyre type	p _{max.} in bar
145 / 80 R10 ; R13	3.0
155 R13 ; RF ; R13C	3.5
155 / 70 R12 ; R12C	6.25
155 / 70 R13	3.0
155 / 80 R13	3.0
175 / 70 R13	3.0
175 / 80 R14	3.0
185 R14C	4.5
185 / 60 R15	3.0
185 / 65 R15	3.0
185 / 65 R14	3.0
185 / 70 R14	3.0
195 R14C	4.5
195 / 50 R13C	6.25
195 / 55 R13C	6.5
195 / 60 R14	3.0
195 / 65 R14	3.0
195 / 65 R15	3.0
195 / 65 R15 RF	3.4
195 / 70 R14	3.0

Table: Tyre size / Tyre pressure

- ▶ Please use the correct tyre pressure as specified in this table.

9.2.2 Gas struts

- The gas struts are intrinsically maintenance-free.
- However, the gas struts are subject to wear that can be reduced by regular maintenance.



The working range of the gas struts is:
- 25 °C to + 60 °C.

Service life, functionality and safety depend largely on ensuring that the gas struts are serviced and maintained regularly.



WARNING

Removing gas struts

The gas struts are under high pressure!
Improper fitting / removal may result in injury to persons
- impact / collision risk!

- ▶ Observe the safety warnings on the gas struts.
 - ▶ Take note of the instructions provided by the gas strut manufacturer. (see gas strut)
 - ▶ Have worn / defective gas struts replaced by qualified staff only.
-
- ▶ Secure the ramp wall / sales hatch against falling when fitting / removing the gas struts.
 - ▶ Exchange worn gas struts in pairs.
 - ▶ Only use gas struts of the same type - take note of the force information.



Do not aim the water jet directly at the gas struts when cleaning.

- ▶ Clean the piston with a clean cloth.
- ▶ Keep films and paper packaging away (electrostatic charge is possible).
- ▶ Do not scratch or paint the piston rod or treat it with aggressive media (abrasives).



Gas struts sales hatch

1. Attachment
2. Gas strut (body)
3. Piston rod
4. Piston rod safety device
5. Support bracket

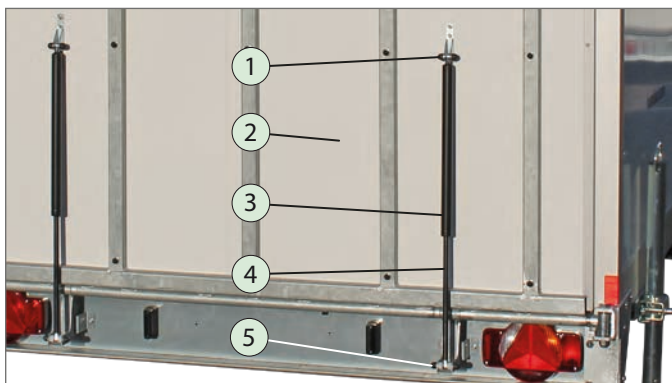

Gas strut of ramp wall

1. Attachment
2. Ramp wall
3. Gas strut (body)
4. Piston rod
5. Support bracket

9.2.3 Espagnolette lock

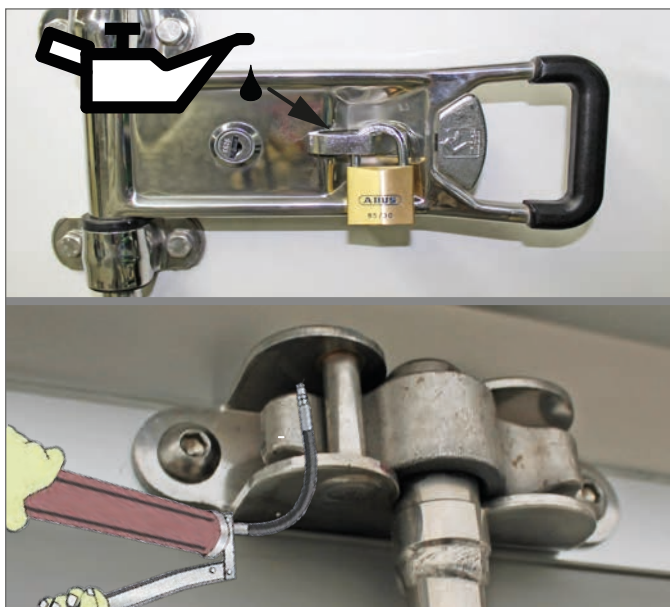

Espagnolette lock

- ▶ Check the espagnolette lock for signs of wear, fracture and secure closing.
- ▶ Clean the locks and the locking mechanism with a dry cloth.
- ▶ Lubricate the locking hooks with grease if required.
- ▶ Lightly oil the movable securing element and the bearing.
- ▶ Remove any excess lubricant.

9.2.4 Distributor box



Distributor box

- ▶ Have maintenance work on the distributor box carried out by qualified electricians.
- ▶  Switch the power supply off prior to carrying out work on the electric system.

9.2.5 Cable winch



The cable winch must be inspected by specialised staff at least once a year or every 10,000 km. If the cable winch is subject to heavy-duty use or operating conditions, the inspection intervals must be shorter.

The cable winch and its attachment must be checked for damage / crushing, ageing, broken individual wires or the cable as a whole and material fatigue.

Servicing work may only be carried out by qualified technical personnel.

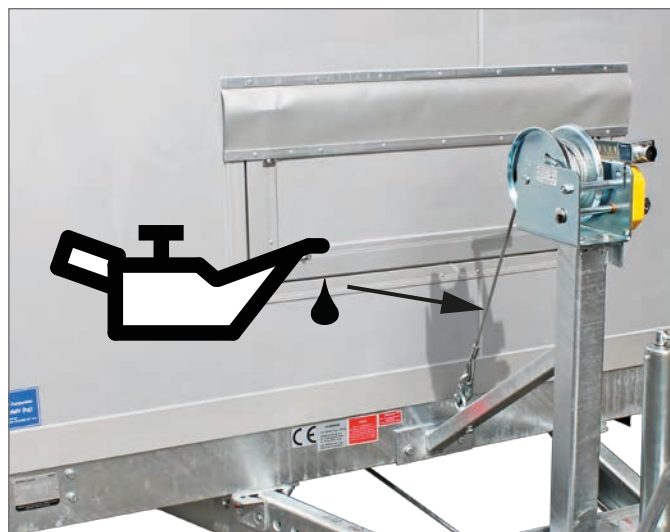

Testing / greasing the cable winch

- ▶ Completely extend the cable and clean both the cable and the gear segments with a clean cloth.
- ▶ Carry out a visual inspection for damage / tears / cracks. - In the event of damage, have the cable winch repaired by qualified technical personnel.
- ▶ Lightly oil the cable with commercially available machine oil.
- ▶ Carefully wind the cable onto the drum.

9.2.6 Refrigerating unit



Refrigerating unit

- ▶ Comply with the maintenance and repair instructions of the refrigerating unit manufacturer.
- ▶ Have your refrigerating unit registered by the manufacturer. This enables a faster response when service is required.
- ▶ Contact your dealer or the hotline of the refrigerating unit manufacturer when service is required.

11 Decommissioning / disposal



Observe the safety instructions for decommissioning / disposal of trailers in the operating instruction manual "Trailers up to 3.5 t" (General Points - Part 1).

11.1 Shutdown

- ▶ Secure your trailer against unauthorised use by third parties, e.g., using immobilisers.
- ▶ Park your trailer so that it cannot cause any additional hazards for third parties, e.g., by tipping over, rolling away or causing a traffic obstruction.

11.2 Disposal

- ▶ Bring the individual parts or the complete trailer to a car / vehicle recycling facility. The specialists at the car / vehicle recycling facility will dispose of the individual components in the proper manner.

10 Troubleshooting

Malfunction	Possible cause	Solution
Ramp wall can only be lifted with difficulty.	- Gas struts are too weak. - Gas struts are defective.	▶ Have the gas struts replaced in a specialist workshop.
The revolving door at the rear or in front cannot be closed.	- Hinges are worn out / deformed - the revolving door has settled.	▶ Slightly lift the revolving door when closing it. ▶ Have the deformed revolving door replaced or repaired in a specialist workshop.
Interior lighting does not light up	- Vehicle lighting is not switched on	▶ Switch on at least the parking light on the towing vehicle.
	- Lamp is defective	▶ Exchange the lamp of the interior light
	- Cable is defective	▶ Have the cable connection from the plug to the interior light checked by a qualified tradesman and repaired if necessary.
Socket 230V without function	- Protective circuit breaker / fuse off	▶ Switch on the protective circuit breaker / fuse. Have the system checked by a qualified tradesman should other faults occur.
	- Cable defective	▶ Have the cable connection checked by a qualified tradesman and repaired if necessary.
Sales hatch does not close tightly at the top	- Sales hatch was closed with momentum without opening the locks. Hinges have been bent.	▶ Have the hinges replaced in a specialist workshop and the sales hatch adjusted if required.

Troubleshooting table

Humbaur wishes you a pleasant & safe journey!





We assume no responsibility for printing or other errors or omissions.
All illustrations are representative.
Deviations and modifications are subject to the model type.
Subject to technical modifications.
Copying prohibited.
Printed in Germany.
Version 2019/01