

COMPLETE RANGE  
**Vehicle transporters**



**For every  
vehicle the  
right  
Trailers**

- 
- 
- 
- 
- 
- 
- 
- 
- 
- 
- 
- 
-

# Experience it for yourself

Our rationale makes it easy for you to become a staunch follower of Humbaaur's high-quality products.



## Follow HUMBAUR!

*'Because HUMBAUR is master of transportation'.*

### **35 years of experience**

We have been one of the leading manufacturers of car trailers for over 35 years. Over 1,000,000 trailers have left our premises since our company was founded. Nowadays, we produce around 60,000 units per year. And our wealth of experience is reflected in each of our trailers.

### **High quality**

Robust and long-lasting — that's what a trailer needs to be. We use outstanding components and first-rate workmanship to achieve this goal. Before we deliver each trailer, we put it through its paces.

### **A wide range of transportation solutions**

Our offering covers a very wide range of uses. Whether you are looking for a trailer for private or commercial needs, we can provide you with the appropriate model. You can choose a maximum gross weight between 750 kg and 55 t.

### **Wide range of accessories**

Do you have very specific demands on your trailer? Thanks to a number of matching accessories, you can add to the comprehensive standard equipment to meet your requirements accordingly.

### **Committed customer service**

If your trailer weighs up to 3.5 t, your specialist dealer in your area will be happy to help. Owners of trailers weighing in excess of 5 t total weight are able to take advantage of our direct service. Whether you need a spare part or have a question about how to use your trailer – we, together with your local dealer, will be happy to help.

### **High-quality components**

Quality is reflected in the detail—that's why Humbaaur only uses high-quality vehicle components produced by reputable manufacturers. We continuously share our experiences with our suppliers. This enables us to keep improving our products.

# Everything at a glance

## Table of contents

Experience it for yourself .....	2
At home on the road .....	4
Motorcycle transporters/small vehicle transporters	
Motorcycle transporters HM.....	6
Motorcycle/small vehicle transporters KFT .....	10
Vehicle transporters	
FTK tilting .....	14
HKT lowering.....	18
Universal high-loader car transporters .....	22
MTK tilting high-loaders.....	26
MTKB vehicle transporters.....	30
Universal transporters	
MTK tilting all-comfort high-loaders.....	34
Senko lowering trailers .....	38
Optional accessories.....	42
About Humbauro .....	46



# The 4000 Series

At home on the road



## Motorcycle transporter

*HM*

The HM motorcycle transporter for up to three motorcycles gets you safely to your destination, whether you are off to the track, to the workshop or on holiday. You can securely fasten your motorcycles to ten galvanised load-securing eyes. A loading ramp is stored in a plank shaft for this purpose under the trailer; it can be assembled in just a few steps. Optional prop stands are available as accessories for all models, as are wheel shock absorbers and a plastic tool box. Your motorcycle trailer can therefore be equipped to meet your every need.



## Small vehicle transporters

*KFT*

The KFT small vehicle and motorcycle transporter is available with two equipment packages that provide for either vehicle or motorcycle transportation. The "vehicle transportation" package includes the mounted plank shaft and two aluminium ramps, along with two prop stands. The "motorcycle transportation" package includes the mounted plank shaft, two loose motorcycle stands, two loose connection brackets and a motorcycle loading ramp. A stand and connection bracket for a third motorcycle are available as an additional option. The aluminium sides are equipped with integrated tie-down hoops. When fitted with the optional 350 mm aluminium side, the Humbaour KFT becomes truly multifunctional.

## Vehicle transporters

*FTK*



Use the new tilting FTK vehicle transporter from Humbaour to transport your vehicle comfortably and safely. The FTK also offers the benefits of tilting vehicle trailers for compact vehicles. Ideal for companies who carry out vehicle repairs or for private users wishing to transport small vehicles such as a Smart or VW Golf. You can use shock absorbers to mechanically tilt the bridge and effortlessly load your vehicle on to the trailer via serrated steel loading ramps. Available with a cable winch and tilting hydraulic mechanism (both optional).

## Small vehicle transporters

*HKT*



The multi-functional versatile Humbaour HKT makes it easier than ever before to transport small vehicles. All HKT trailer models are fitted as standard with a bolted and hot-dip galvanised chassis. The hydraulically lowering loading area allows you to load and unload the trailer comfortably and conveniently at a very low ramp angle. One of the features of the new single-axis HKT lowering trailer is the ramp front edge at the rear. Standard equipment also includes slots in each corner.

## Vehicle transporters

*MTK*



Its extremely robust and durable design makes the MTK, available in tandem axle, the ideal trailer for anyone wishing to transport professional vehicles. With a total permissible weight of between 2500 and 3500 kg, it can also be used to transport heavier passenger vehicles. The frame and chassis are hot-dip galvanised. The cable winch, which can be adjusted lengthways, is mounted on a robust frame. The vehicle can be driven over extendible, hot-dip galvanised steel ramps at a slight angle on to the trailer. An optional hydraulic mechanism lifts the bridge for this purpose. Load-securing options, each with 400 kg of tensile force, are positioned in the side of the outer frame to secure the load.

## Universal transporters

*MTK Allcomfort*



Makes every application as easy as possible for you. Simply use a manual pump to tilt the hydraulic bridge. Pneumatic springs will help you to operate the ramp gate. Thanks to the low loading height of 650 mm, the ramp angle remains very flat. This means you can easily load machinery and vehicles that are in a lower lying position. A robust, optional cable winch frame with cable winch is provided on the trailer to help you load effortlessly. The sophisticated chassis technology of the MTK Allcomfort provides for an extremely quiet ride.

## Vehicle transporters

*Universal*



The solid base plate, placed on the transporter's hot-dip galvanised chassis and frame, can be used for almost all transportation options. The vehicle can be loaded onto the universal trailer by means of two corrosion-resistant drive-up ramps. The entire width of the ramps can be adjusted, meaning they can be precisely adapted to the track width of the vehicle. The ramps can then be slid under the loading area. The load can be secured to seven load-securing rings for safe transportation. An aluminium instead of wooden floor, aluminium side panels, and tarpaulin with frame can be retrofitted at any time.

## Lowering trailer

*Senko*



The Senko goes out of its way to help and can also accommodate vehicles with low ground clearance. The loading area can also be hydraulically lowered easily by means of a manual pump or you also have the option of lowering it electronically, making life even easier. Its retractable rubber spring axles give you an almost level loading angle. This makes the Senko extremely robust. The 3 mm-thick steel plate side panels can withstand large loads. Each of the ten load-securing rings has been tested by DEKRA to a tensile load of 800 kg. Of course, all vehicle components are hot-dip galvanised.

## Vehicle transporters

*MTKB*



The MTKB impresses with its astute design and reliability. Thanks to the closed box body made of GFRP sandwich panels, its load remains dry and hidden from view during transport. It can easily accommodate many types of vehicle: from sports cars to classic cars through to vans and SUVs. It's easy to manually secure the load. The two stand rails combined with the wheel stops and lashing straps enable you to secure your load easily and above all reliably. The handy electrical cable winch can be adjusted transversely, making it possible to load unroadworthy vehicles too. Using the optional accessories such as the left and right double-wing doors and the additional access doors to the front and rear, your vehicle can be secured in next to no time from the inside of the trailer, even on narrow roads.

# MOTORCYCLE TRANSPORTER **HM**



# HM

## Ready to transport three stylish motorcycles

The HM motorbike transporter for up to three motorbikes takes you safely to your destination - to the track, to the workshop or on holiday. No matter where you want to transport your motorbikes, you will find the right motorbike trailer at Humbaaur. The HM motorbike transporter for three motorbikes is equipped with three stand rails. You can securely fasten your motorbikes to 10 galvanised lashing eyes. A ramp rail for loading is located in its own plank shaft under the trailer, and assembly is possible in just a few steps. The

HM motorbike transporter for three motorbikes is available in an unbraked and a braked version. On the braked model, a trailer support wheel is standard equipment. Optional prop stands are available as accessories for all models, as are wheel shock absorbers (with and without 100 km/h approval) and a plastic toolbox. This way, your motorbike trailer can be equipped for every motorbike transport need.

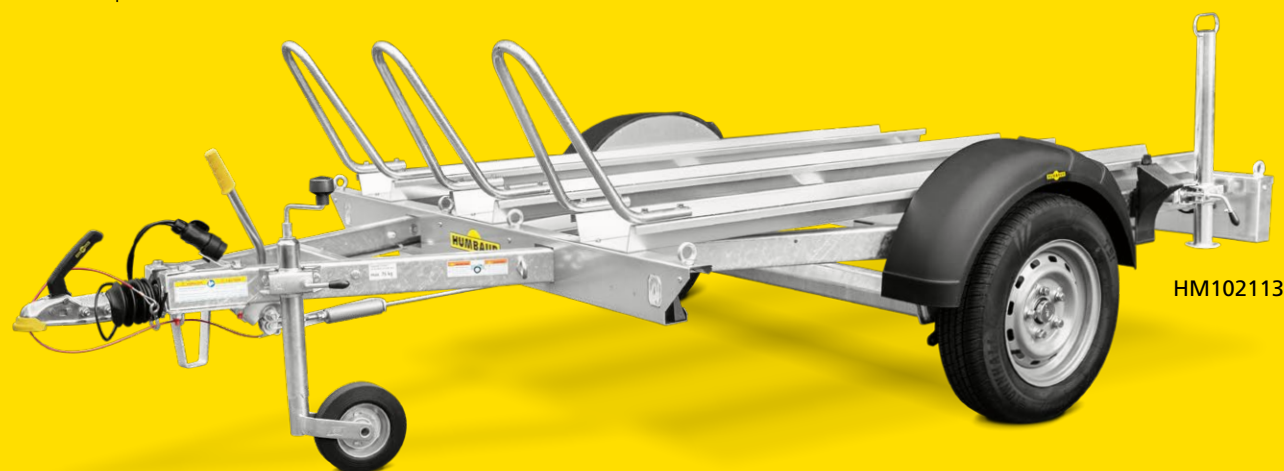

HM102113

# Motorradtransporter HM

## Technical Data

### HM 752113

Overall dimensions	3142 × 1765 × 980 mm
Interior dimensions	2095 × 1365 × 70 mm
Total permissible weight	750 kg
Load capacity	575 kg
Load height	515 mm
Tyres	13"
Ramp angle	15°

### HM 102113

Overall dimensions	3195 × 1765 × 990 mm
Interior dimensions	2095 × 1365 × 70 mm
Total permissible weight	1000 kg
Load capacity	789 kg
Load height	535 mm
Tyres	13"
Ramp angle	15°



HM 75 21 13





## IMPORTANT DETAILS

- V drawbar hot-dip galvanised
- 13-pin plug and reversing light
- 10 galvanised lashing eyes for load securing
- 3 stand rails with stirrup mounted
- Drive-on rail integrated in the screed shaft
- Humbaur multifunctional lighting

## ACCESSORIES (OPTIONAL)

- 2 pcs. prop stands
- Support wheel
- Spare wheel
- Wheel shock absorber loose / mounted
- Adapter 7 - 13-pole
- Plug lock (unbraked trailers)
- Toolbox

## THE IDEAL PARTNER

FOR MOTORBIKE SPORT

Place for 1 2 3



Fastening for lashing straps



3 stand rails with bracket mounted



1 ramp rail integrated in the plank shaft



Large-dimensioned quality tyres for a smooth ride even on poor road surfaces

# MOTORCYCLE TRANSPORTER **KFT**



# KFT

## Designed to transport one small car or up to three motorbikes

The small vehicle and motorbike transporter KFT is available with two equipment packages: for vehicle transport and for motorbike transport. The 'vehicle transport' equipment package includes, in addition to the mounted plank shaft, two aluminium drive-on ramps and two push supports with which the trailer is stabilised during loading and unloading. The 'Motorcycle transport' equipment package includes, in addition to the mounted plank shaft, two loose motorbike rockers, two loose tie-down brackets and a motorbike

drive-on rail. Rocker and tie-down bracket for a third motorbike are optionally available. The aluminium drop sides are equipped with integrated lashing brackets. The enlarged loading area also offers space for somewhat larger small cars or up to three motorbikes. The new Humbaaur KFT becomes a true multi-talent with the optionally available 350 mm aluminium drop side. Then the trailer can also prove itself in other transport challenges and compete with classic box trailers.

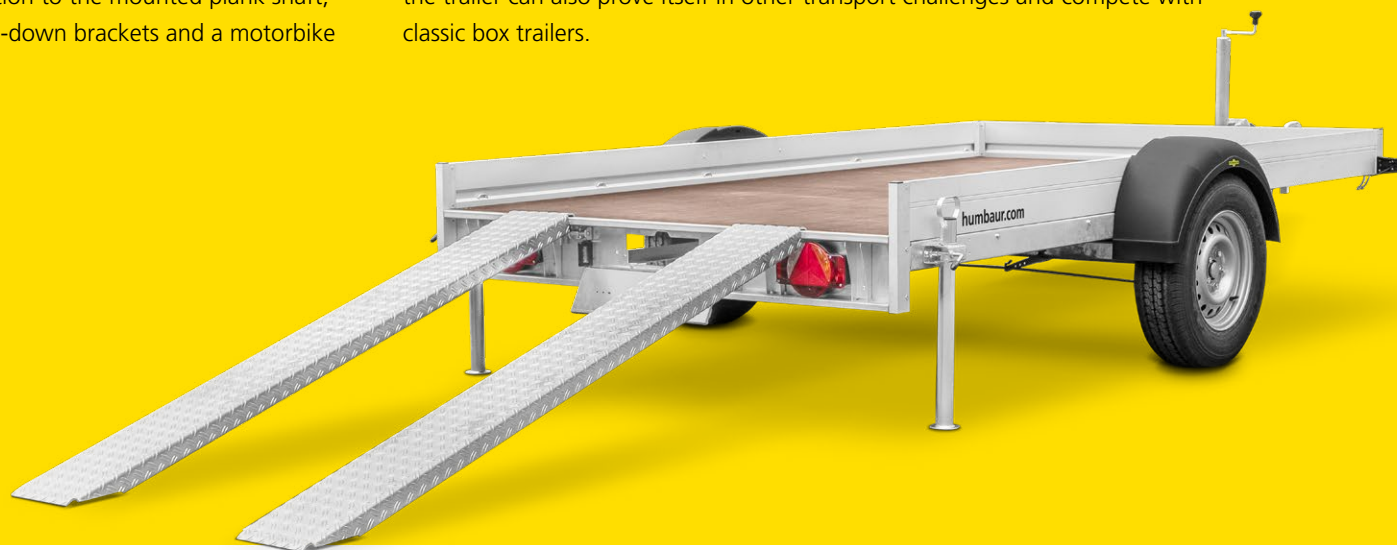

# Motorcycle Transporter KFT

## Technische Daten

### KFT 153117 ALU

Overall dimensions	4445 × 2260 × 930 mm
Interior dimensions	3115 × 1765 × 150 mm
Total permissible weight	1500 kg
Load capacity	1196 kg
Load height	570 mm
Tyres	14"



## IMPORTANT DETAILS

- V drawbar hot-dip galvanised
- 13-pin plug
- Base plate 15 mm
- 10 lashing options in the side aluminium drop side
- Support wheel fully automatic
- Accessory package vehicle transport or Motorbike transport (optionally available)
- Humbaur multifunctional lighting and reversing light
- Wheel shock absorber (optional accessory)

## ACCESSORIES (OPTIONAL)

- 2 x prop stands
- Spare wheel
- Loose wheel shock absorbers
- Fitted wheel shock absorbers
- Side plate height 350 mm
- Vehicle transporter package
- Motorcycle transporter package

### ACCESSORY KIT Fahrzeugtransporter

- Plank shaft
- 2x Aluminium loading ramps
- 2x Prop stand mounted



### ACCESSORY KIT Fahrzeugtransporter

- Plank shaft
- 2x loose motorcycle stands
- 2x loose connection brackets
- 1x motorcycle loading ramp

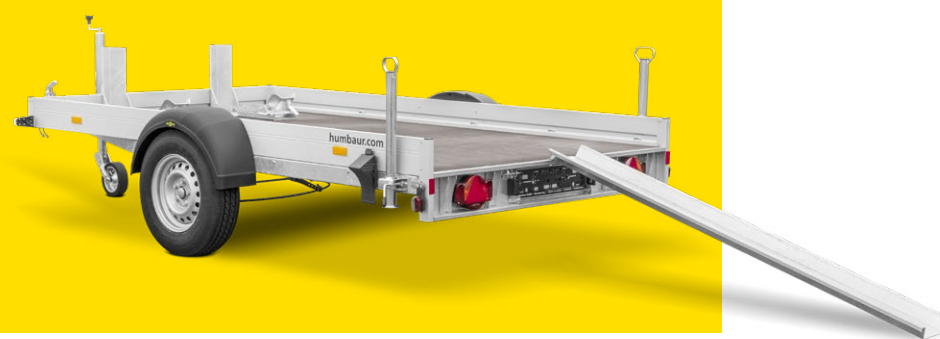

# VEHICLE TRANSPORTER **FTK**



# FTK

## It is indestructible, flexible and really gets things done

With the new FTK tiltable vehicle transporter from Humbaer, you can transport your vehicle comfortably and safely. The FTK now offers the advantages of tiltable vehicle trailers in the compact class. Ideal for vehicle repair service companies or private users for transporting small vehicles such as a Smart or VW Golf. The sturdy

construction, well thought out in detail, ensures an optimally utilised usable space and a low loading angle. Galvanised components and the numerous load securing options confirm the quality in detail of Humbaer.



FTK 15 35 20

# Vehicle Transporter FTK

Permissible gross weight in kg	Model	Overall dimension in mm	Internal dimensions in mm	Load capacity in kg	Load height in mm	Tyres in inches	Ramp angle
1300	HUK 132314	3650 x 1540 x 950	2300 x 1400 x 300	900	640	13	45°
1500	HUK 152314	3650 x 1540 x 950	2300 x 1400 x 300	1100	640	13	45°
1500	HUK 152715	4130 x 1640 x 980	2680 x 1500 x 300	1025	670	13	45°

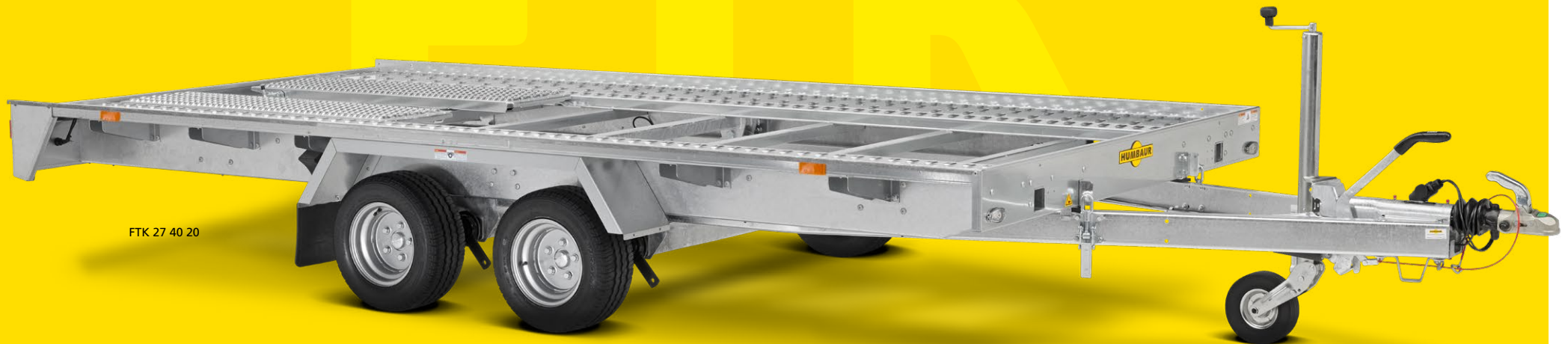

FTK 27 40 20



## IMPORTANT DETAILS

- Chassis bolted and galvanised
- Galvanised tipper bridge
- Base plate 15 mm
- Hot-dip galvanised steel drive-on rails
- V drawbar hot-dip galvanised
- 13-pin plug
- jockey wheel
- Optional winch stand with cable winch
- Optional wheel stop on the adjustable stand rails
- Humbaур multifunctional lighting and reversing light

## ACCESSORIES (OPTIONAL)

- Wheel shock absorber loose
- Winch stand with winch
- Wheel stop 360 mm
- Spare wheel bracket for the FTK (loose) & spare wheel
- Loose wheel shock absorbers
- Fitted wheel shock absorbers
- 7-pin to 13-pin adapter
- Passenger vehicle lashing strap, 50 mm belt width, length 2500 mm
- Automatic jockey wheel
- Hydraulics with double-acting cylinder for tilting the loading area
- Spare wheel with holder



Optional wheel stop for load securing

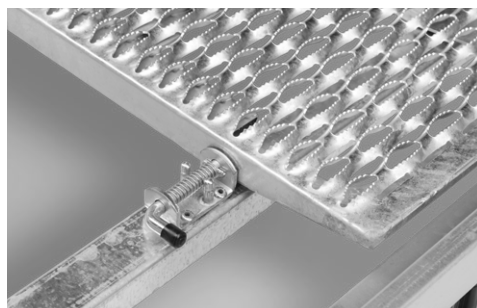

Easy handling for attaching the steel ramp rails



Shock absorber for the mechanical tilt function

# VEHICLE TRANSPORTER **HKT**



# HKT

## Designed for the transport of Motorbikes or small vehicles

On the road with a motorhome, quad bike, motorbike, scooter or small car? It's possible with our HKT. So if you don't want to miss out on your hobby on holiday or want to be additionally mobile, our vehicle transporter HKT is just the thing for you. The practical trailer has space so that you are also mobile on the road and don't have to repack the erected awning every time.



# Vehicle Transporter HKT

Permissible gross weight in kg	Model	Overall dimension in mm	Internal dimensions in mm	Load capacity in kg	Load height in mm	Tyres in inches	Ramp angle
750	HKT 752515 S	4050x2250x660	2500x1565x150	450	420	13	6
1350	HKT 132515 S	4085x2250x660	2500x1565x150	1018	420	13	6
1500	HKT 152515 S	4085x2250x660	2500x1565x150	1168	420	13	6
1800	HKT 182515 S	4085x2250x660	2500x1565x150	1470	420	13	6
1350	HKT 133117 S	4610x2450x670	3100x1765x150	985	420	13	4
1500	HKT 153117 S	4610x2450x670	3100x1765x150	1135	420	13	4
1800	HKT 183117 S	4610x2450x670	3100x1765x150	1415	420	13	4

Off on camping holiday with the HKT



## IMPORTANT DETAILS

- geschraubtes, feuerverzinktes Fahrgestell
- Ladefläche hydraulisch absenkbar
- mechanische Sicherheitsverriegelung der Schwenkachse im Fahrbetrieb
- Humbaur Multifunktionsbeleuchtung mit Rückfahrcheinwerfer
- mit Überfahrspitz hinten
- Nummerschildhalter hinten, zum Beladen wegschwenkbar
- Holzboden 15 mm stark
- Seitenwände aus Aluminum 150 mm hoch mit integrierten Zurringen (Zugkraft 400 kg pro Zurring, Dekra geprüft)
- Einsteckmöglichkeiten an allen Ecken für z.B. Planengestell
- 13-poliger Stecker
- Handpumpe zum Heben und Senken der Ladefläche

Hand pump with oil reservoir



Foldable licence plate holder



▲ Lashing rings with Humbaur lashing strap ▼ Detail view rear

## ACCESSORIES (OPTIONAL)

- Loose wheel shock absorbers
- Fitted wheel shock absorbers
- Tarpaulin & frame, blue, load height 1600 mm/1800 mm, for optional gate
- Motorcycle stand
- Spare wheel
- 7-pin /13-pin adapter
- Mortise lock for unbraked trailers
- 350 mm side panels
- Tailgate instead of ramp front edge
- Toolbox on tow bar



# HIGH-LOADER **UNIVERSAL**



# UNIVERSAL

## Universally applicable - in the truest sense of the word

On its hot-dip galvanised chassis and frame lies a continuous floor plate for almost universal transport possibilities. You load the Universal loader with two drive-on planks that are also protected against corrosion. Move the planks to adjust them exactly to the track width of the vehicle. Then simply slide the planks under the loading area. Secure the load to seven lashing rings for a safe stand. You can retrofit an aluminium instead of wooden floor, or aluminium side walls, but also a tarpaulin with frame at any time.



# Hochlader Universal

Permissible gross weight in kg	Model	Overall dimension in mm	Internal dimensions in mm	Load capacity in kg	Load height in mm	Tyres in inches	Ramp angle
3000	Universal 3000 - Holz	5374 x 2034 x 830	4000 x 2030	2310	600	10	13
3000	Universal 3000 - Alu	5374 x 2034 x 830	4000 x 2030	2320	600	10	13
3500	Universal 3500 - Holz	5405 x 2050 x 890	4000 x 2030	2670	670	13	15
3500	Universal 3500 - Alu	5405 x 2050 x 890	4000 x 2030	2720	670	13	15

UNIVERSAL



Universal 3500 - Alu



## IMPORTANT DETAILS

- Screwed-in V drawbar hot-dip galvanised
- 13-pin plug
- Base plate, 18 mm thick
- Two hot-dip galvanised drive-up ramps, grated, inserted under the loading area
- Two supprotimng feet (Universal 3500)
- Seven load securing rings in each side in the outer frame profile
- Perforations for wheel stop un zhe outer frame profile
- Cable winch with cable amd three-way depth-adjustable bracket
- Automatic jockey wheel (Universal 3000)
- Jockey wheel with large wheel spool (Universal 3500)
- Humbaur multifunctional lighting with reversing lights

Stable base frame made of folded steel profiles



## ACCESSORIES (OPTIONAL)

- Spare wheel
- Spare wheel bracket
- Spare wheel bracket under the loading area
- Loose wheel shock absorbers
- Fitted wheel shock absorbers
- Universal wheel stop
- 800 mm high H-frame
- 350 mm side panels extension
- 350 mm side panels
- Passenger vehicle lashing strap, 50 mm belt width / 2500 mm
- Tarpaulin & frame, load height 1800 mm/2000 mm; in colour of your choice
- Support feet
- Tool box

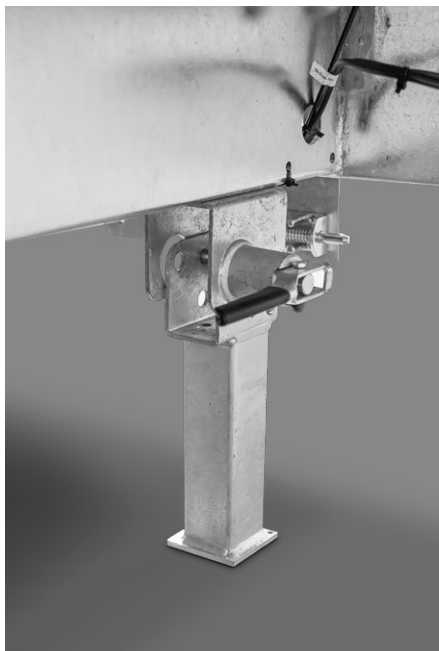

Support feet



Hot-dip galvanised steel drive-up ramps

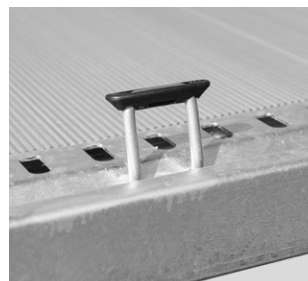

Lashing eyes

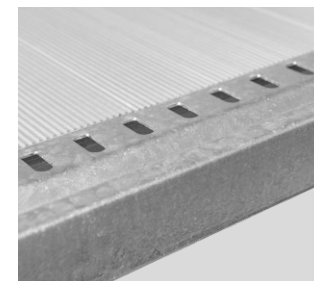

Wheel stop eyelets

# VEHICLE TRANSPORTER MTK



# MTK

## Extremely robust and durable - for real professional vehicle transport

Its extremely robust and durable design makes the MTK as a tandem axle trailer the ideal trailer for anyone who transports vehicles professionally. With a permissible total weight between 1500 and 3500 kg, you can also transport heavier cars safely. Frame and chassis are hot-dip galvanised. The longitudinally adjustable cable winch is mounted on a stable trestle. On ex-

tendable, hot-dip galvanised steel planks, you drive the vehicle over a small ramp angle onto the trailer. An optional hydraulic system raises the bridge for this purpose. For safe lashing of the load, lashing possibilities with 400 kg tensile force each are available in the lateral outer frame.



# Fahrzeugtransporter MTK

Total permissible weight in kg	Model	Overall dimension in mm	Internal dimensions in mm	Load capacity in kg	Load height in mm	Tyres in inches	Ramp angle
3000	MTK 304222	5700 x 2180 x 900	4200 x 2180	2280	650	13	11
3500	MTK 354222	5700 x 2180 x 900	4200 x 2180	2720	650	13	11
3000	MTK 304722	6200 x 2180 x 900	4700 x 2180	2240	650	13	11
3500	MTK 354722	6200 x 2180 x 900	4700 x 2180	2680	650	13	11



MTK 30 47 22



MTK 30 47 22

## IMPORTANT DETAILS

- Bolted, hot-dip galvanised chassis
- Welded, hot-dip galvanised tilting bridge
- Tilting bridge mechanically tilted using pneumatic pressure absorbers
- Steel loading ramps can be pulled out from under the loading area
- Lengthways adjustable cable winch
- Perforated standing area
- Six pairs of load-securing points in the outer frame where length is 3600 and 4200, each with 400 kg of lashing capacity
- Eight pairs of load-securing points in the outer frame where length is 4700,

## ACCESSORIES (OPTIONAL)

- Tarpaulin & frame load height 1800 mm / 2000 mm
- Fitted / Loose wheel shock absorbers
- 350 mm aluminium side panels
- Wooden / Aluminium floor, stand rails removed
- Wooden floor between stand rails
- Double-acting cylinder for tilting the loading area
- Five-way transversely adjustable cable winch
- Electric cable winch, adjustabler



MTK 35 47 22



In the plank shaft insertable hot dip galvanised steel planks

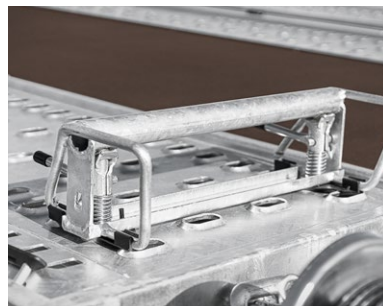

Special stability due to double hat profiles attached to the bridge in the transverse direction



Bridge with special tilt bearing



Extreme stability thanks to a bolted, riveted and bolted bridge with continuous longitudinal bridge girders

# VEHICLE TRANSPORTER MTKB



# MTKB

## Transport sports cars and classic cars safely and comfortably

Race track, holiday, classic car meeting - you don't always want to drive your valuable vehicle to its destination. But what then? With a reliable vehicle transporter, the vehicle can be transported easily and comfortably. The MTKB 355724-22 offers plenty of space and scores with well thought-out details. One thing is certain: the cargo travels well protected.



# Vehicle Transporter MTKB

## TECHNICAL DATA

### MTKB 35 57 24-22

Overall dimensions	7531 x 2481 x 2818 mm
Internal dimensions	5726 x 2334 x 2086 mm
Total permissible weight	3500 kg
Load capacity	2000 kg
Load height	650 mm
Tyres	13"





## IMPORTANT DETAILS

- Stand rails approx. 700 mm wide for perfect load securing
- Aluminium folding ramp with specially low ramp angle
- Double-wing doors on both sides for loading and unloading
- Double-wing doors on both sides for loading and unloading
- 1 Permitted to travel at 100 km/h

Electric winch with 3.6 t pulling force



Spare wheel



Loading ramp



**MTKB MTKB MTKB MTKB MTKB MTKB MTKB MTKB MTKB MTKB**

# HIGH-LOADER **MTKA**



# MTKA

## Convenient and easy Loading and unloading of the trailer

It makes every operation as comfortable as possible for you: You simply tilt the hydraulic bridge with a hand pump, gas springs support you in operating the ramp wall. Thanks to the low loading height of 650 mm (tandem axle), the ramp angle remains very flat. A stable, optionally available winch stand with cable winch is available so that you can easily get the vehicles onto the trailer. The sophisticated chassis technology of the MTK Allcomfort ensures exceptionally smooth handling.



MTKA 35522

# Hochlader MTKA

Total permissible weight in kg	Model	Overall dimension in mm	Internal dimensions in mm	Load capacity in kg	Load height in mm	Tyres in inches	Ramp angle
3000	MTKA 304222	5750 x 2305 x 1690	4200 x 2180 x 200	2130	650	13	10
3500	MTKA 354222	5750 x 2305 x 1690	4200 x 2180 x 200	2580	650	13	10
3500	MTKA 354722	6250 x 2305 x 1690	4700 x 2180 x 200	2535	650	13	9



## ACCESSORIES (OPTIONAL)

- Fitted wheel shock absorbers
- 2 x cantilever rods for tailgate, loose
- 350 mm-high aluminium side panels
- Five-way adjustable cable winch
- Adjustable electric cable winches
- Aluminium floor instead of wooden floor

## IMPORTANT DETAILS

- Bolted, hot-dip galvanised chassis
- Welded, hot dip galvanised tilting bridge
- Double-acting cylinder for tilting the loading area
- Ramp gate, perforated with pneumatic spring support
- Side panels made if anodised aluminium
- Load securing points in the outer frame with 400 kg of lashing capacity
- Optional five-way transversely adjustable cable winch
- Base plate, 18 mm thick and wheater resistant

MTKA 354722 with 350mm high drop sides, available as an option



Perforated ramp wall folded up with Gas spring support



Special stability due to double hat profiles in transverse direction on the bridge



Electric cable winch

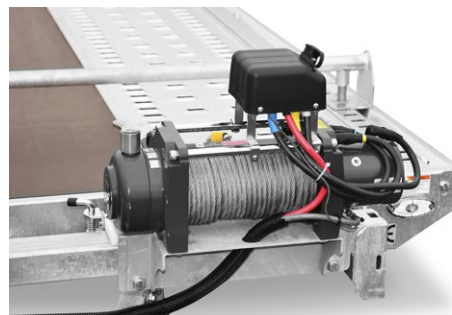

Hot dip galvanised corner stanchions and Tension locks

# LOWERING TRAILER SENKO



# SENKO

## Our lowerable all-rounder - stable and durable

The Senko is happy to accommodate you and also takes vehicles with low ground clearance. To do this, you can conveniently lower the loading area hydraulically with a hand pump or, optionally, even more conveniently electrically. Its lowerable rubber spring axles provide you with an almost level loading

angle. At the same time, the Senko is enormously robust. The drop sides are made of 3 mm thick sheet steel and can withstand the greatest loads. Each of the ten lashing rings has been tested by Dekra for a tensile load of 800 kg. Of course, all vehicle components are hot-dip galvanised.

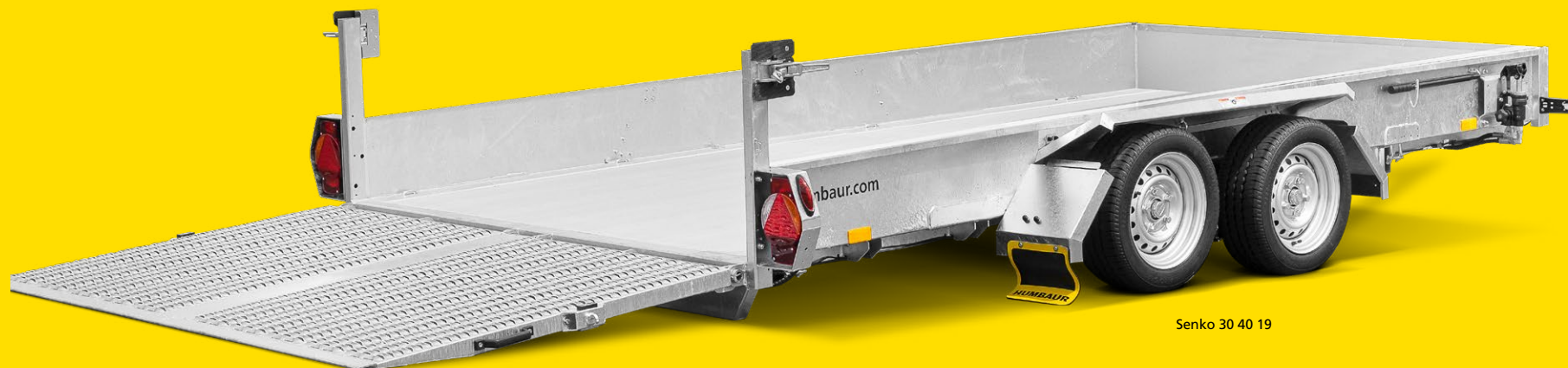

Senko 30 40 19

# Lowering Trailer Senko

# SENKO

Total permissible weight in kg	Model	Overall dimension in mm	Internal dimensions in mm	Load capacity in kg	Load height in mm	Tyres in inches	Ramp angle
3000	Senko 303016	4750 x 2230 x 1740	3000 x 1600 x 270	2260	470	13	7
3500	Senko 353016	4680 x 2230 x 1740	3000 x 1600 x 270	2740	470	13	7
3000	Senko 303718	5500 x 2480 x 1740	3750 x 1850 x 270	2140	470	13	7
3500	Senko 353718	5470 x 2480 x 1740	3750 x 1850 x 270	2620	470	13	7



Senko 30 37 18



## IMPORTANT DETAILS

- Welded side plate/frame construction made of sheet steel, hot-dip galvanised
- Bolted V drawbar, hot-dip galvanised
- 13-pin plug and reversing lights
- Hot-dip galvanised ramp gate with non-slip mesh surface and pneumatic spring support (height approx. 1240 mm, axle load tested to 2500 kg)
- Load-securing rings fitted x 10 in the outer frame (5 pairs) for 3000 mm and x 12 (6 pairs) for 3750/3990 mm body length, tensile force 1000 kg for each load-securing ring
- Fully automatic jockey wheel
- Steel mudguard, automatically opens and closes during the lowering process
- Lighting mounted on the sides
- Hydraulic lowering mechanism with manual pump

## ACCESSORIES (OPTIONAL)

- Spare wheel
- Spare wheel bracket
- Side perforated rail
- Cable winch frame cpl. for lowering mechanism
- Cable winch with cable and pulley where there is an electric pump
- Alu-Swiss ramp gate instead of steel ramp gate
- Hot-dip galvanised tow ar box
- H-frame
- Pump combined with emergency manual pump where there is a V tow bar
- Tarpaulin & frame, (1800 / 2000 mm) in colour of your choice
- Aluminium chequer plate floor



Senko 30 37 18

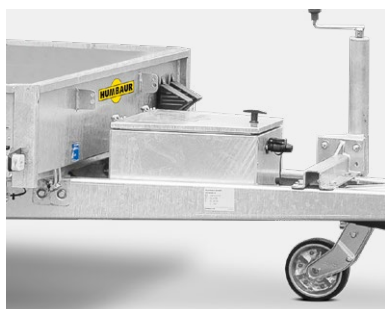

Drawbar box to protect the battery and the lowering hydraulics





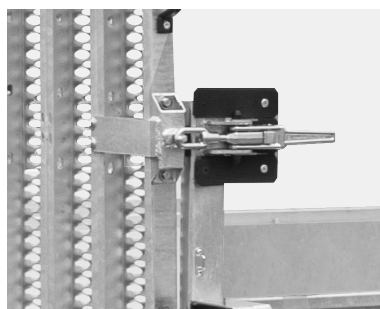

Hot-dip galvanised ramp wall with anti-slip grid covering, as well as with gas spring support





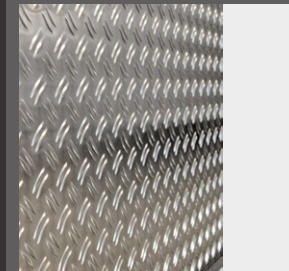

Steel mudguards, automatically opening and closing during the lowering process

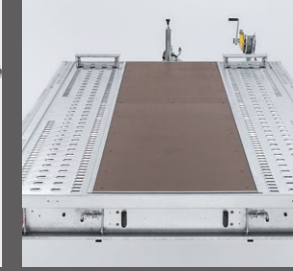
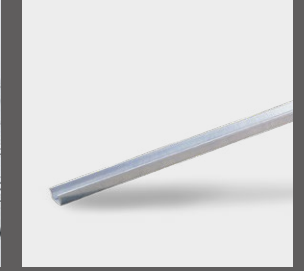
# Our range of accessories

**Body**

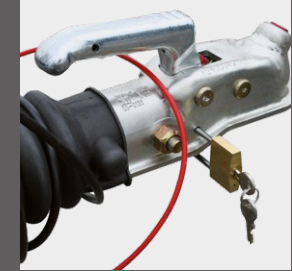
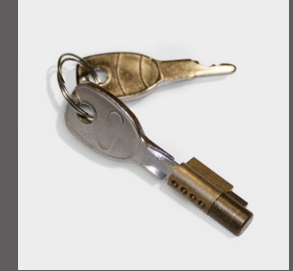
		
<p>Base plate coated with aluminium chequer plate</p>	<p>Cable winch with traction cable and pulley or cable winch frame</p>	<p>Stand rail with hoop (enclosed separately)</p>
		
<p>Doppeltwirkender Zylinder</p>	<p>Loading area, sealed throughout with phenolic resin-coated plywood</p>	<p>Additional loading ramp, loose (1 piece)</p>

**Anti-theft device**

		
<p>Padlock for braked trailers up to 3500 kg</p>	<p>Mortise lock for unbraked trailers</p>	<p>Metal locking shoe with lock</p>
		
<p>Anti-theft Safety Compact</p>		

# Tailored to your requirements

## Wheels



Spare tyres



Wheel shock absorbers incl. 100 km/h confirmation



## Lighting/electrics



7-pin to 13-pin adapter/13-pin to 7-pin adapter

## Chassis



AKS safety clutch



Wheel shock absorbers (loose)



Prop stands (x 2)

# Our range of accessories



## Securing loads



Lashing rings mounted and recessed into wooden floor



Fittings for load securing rail (x 4)



Fittings for airline rail

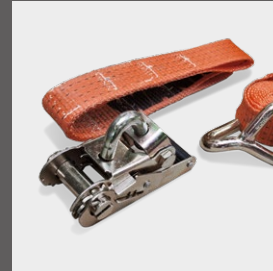

Wheel lashing strap, 50 mm wide



Motorcycle strap, 25 mm (x 4)



Optional wheel stop for securing the load



Motorcycle stands



Wheel stop (locking bar)



Load securing rail



Slotted tie-rail with locking bar



Barred tie-rail with locking bar

# Tailored to your requirements

## Tarpaulin standard colours



White/similar to RAL 9010



Yellow/similar to RAL 1003



Orange/similar to RAL 2011



Red/similar to RAL 3002

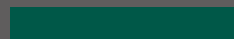

Green/similar to RAL 6026



Blue/similar to RAL 5002



Grey/similar to RAL 7038

Please note that the colours shown may vary from the original colours.

We are happy to create **customised** signage on tarpaulins on request

In addition to the **extensive standard equipment** for our trailer and vehicle bodies, we offer a wide selection of accessories **to suit each model.**

This means that you can **configure** just the right solution for your transport needs based on **your individual requirements** and they can grow alongside your transport requirements.



Order spare parts – conveniently online

[shop.humbaур.com](http://shop.humbaур.com)



# Strengthened by experience

**Humbaur stands for** innovation and customer-oriented solutions. This approach has enabled this owner-managed, medium-sized family business to become the **European market leader**. With around **420 different standard trailer models** ranging from 750 kg to 55 tonnes for commercial and private clients and 230 models of the FlexBox vehicle bodies, it has the perfect solution to every transport problem. For over 35 years, we have built a wealth of experience, together with our trading partners and customers that is reflected in each of our products – **in sophisticated functions and details, greater user-friendliness and a high level of driving comfort.**

Our trademarks include robust and low-maintenance vehicles with an extensive range of standard equipment and wide range of accessories, plus the ability to offer customised solutions. Our own manufacturing expertise—ranging from small metal parts to polyester roofs or sandwich panels—combined with quality components from renowned manufacturers, ensures **durable products which retain their value well.**



Ulrich Humbaur  
Proprietor, Director

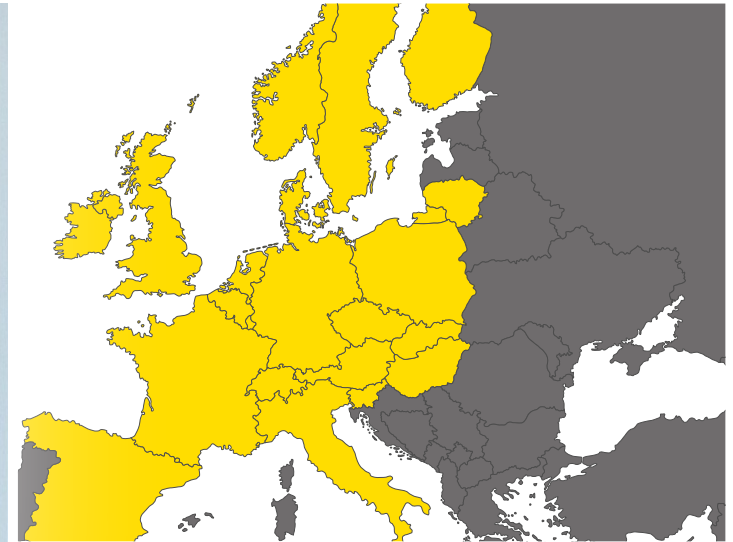

Together with our **partner network**, we provide comprehensive local support for all your transport problems. Together, we will find the right solution for your transport requirements and will take care of **servicing and repairs**. Our service includes reasonably priced repair options and the **long-term availability of spare parts**, so that you can enjoy and use your trailer or vehicle body for years to come.

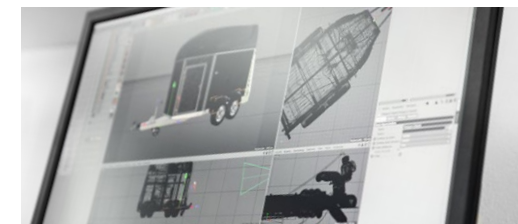

# Outstanding quality

We place great importance on the fact that our products operate even under **tough conditions** with no nasty surprises.

We construct our trailers in robust designs using suitable materials of the required strength. We simulate the hardest conceivable use for our trailers on various test tracks. We check the stability and durability of the chassis, frame and components at full load. This is how we ensure the **outstanding quality** of our trailers.



Our **quality management system** is certified according to **DIN EN ISO 9001:2015 and KBA-ZM-A** and is regularly reviewed. We are also certified by numerous commercial vehicle manufacturers as a construction and reconstruction partner for the vehicle body segment. We can regularly document **our quality promise** through recurring checks and through our products themselves.

As a customer, you benefit from this twice:  
**While using and when reselling.**





More information is available online at  
[humbaur.com/en/dealersservice/downloads/](https://www.humbaur.com/en/dealersservice/downloads/)

Do you have any questions about this or another trailer from our range or would you like a personal consultation?  
We look forward to hearing from you.

Contact us by phone on **+49 (0)821 24 929 - 0** or by email at  
[info@humbaur.com](mailto:info@humbaur.com)

**YOUR HUMBAUR CONTACT IN YOUR AREA**

